

# E- PIONEER

**ALMOST READY TO FLY**

MS:X9



## Specifications

Wing Span	-----61.4 in-----	-----156cm.
Wing Area	-----606.1 sq.in-----	-----39.1 dm. <sup>2</sup>
Weight	-----4.0 lbs - 4,8lbs -----	----- 1800 - 2200g.
Length	-----45.9 in-----	----- 116.6cm.
Ep Motor	-----	----- 4CELLS.

## ***Need to Complete***

Speed Control: 50 - 70 amp.

Recommended Battery 4-cell 2200mAh to 3200mAh Li-Po.

Radio : 4 channel with 5 digital servos ( medium size )

## Kit features.

- Ready-made—minimal assembly & finishing required.
- Ready-covered covering.
- Photo-illustrated step-by-step Assembly Manual.

Made in Vietnam.

## INTRODUCTION.

Thank you for choosing the **E- PIONEER** ARTF by SEAGULL EP. The **E- PIONEER** was designed with the intermediate/advanced sport flyer in mind. It is a airplane which is easy to fly and quick to assemble. The airframe is conventionally built using balsa, plywood to make it stronger than the average ARTF , yet the design allows the aeroplane to be kept light. You will find that most of the work has been done for you already. Flying the **E- PIONEER** is simply a joy.

This instruction manual is designed to help you build a great flying aeroplane. Please read this manual thoroughly before starting assembly of your **E- PIONEER**. Use the parts listing below to identify all parts.

## WARNING.

**Please be aware that this aeroplane is not a toy and if assembled or used incorrectly it is capable of causing injury to people or property. WHEN YOU FLY THIS AEROPLANE YOU ASSUME ALL RISK & RESPONSIBILITY.**

If you are inexperienced with basic R/C flight we strongly recommend you contact your R/C supplier and join your local R/C Model Flying Club. R/C Model Flying Clubs offer a variety of training procedures designed to help the new pilot on his way to successful R/C flight. They will also be able to advise on any insurance and safety regulations that may apply.

## ADDITIONAL ITEMS REQUIRED.

- EP MOTOR



- Battery: Power battery 4cells  
2200 mAh - 3200 mAh.

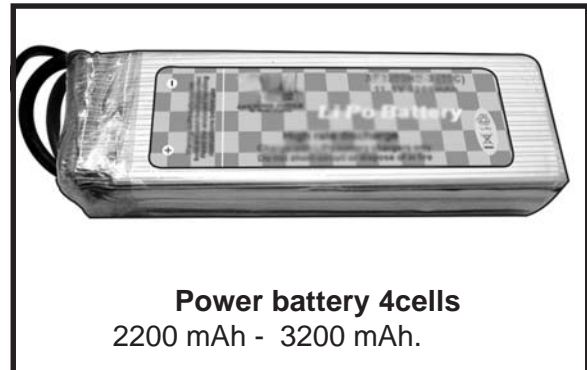

- Speed control: 50A to 70A.

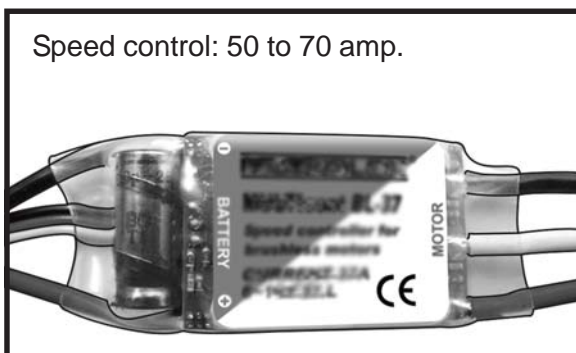

- Radio : 4 channel with 5 digital servos  
(mediumsize).

## TOOLS & SUPPLIES NEEDED.

- Thick cyanoacrylate glue.
- 30 minute epoxy.
- 5 minute epoxy.
- Hand or electric drill.
- Assorted drill bits.
- Modelling knife.
- Straight edge ruler.
- 2mm ball driver.
- Phillips head screwdriver.
- 220 grit sandpaper.
- 90° square or builder's triangle.
- Wire cutters.
- Masking tape & T-pins.
- Thread-lock.
- Paper towels.

**NOTE:** To avoid scratching your new aeroplane we suggest that you cover your workbench with an old towel. Keep a couple of jars or bowls handy to hold the small parts after you open the bags.

Please trial fit all parts. Make sure you have the correct parts and that they fit and are aligned properly before gluing! This will ensure proper assembly as the **E-PIONEER** is made from natural materials and minor adjustments may have to be made.

The paint and plastic parts used in this kit are fuel proof. However, they are not tolerant of many harsh chemicals including the following: paint thinner, cyano-acrylate glue accelerator, cyanoacrylate glue de-bonder and acetone. Do not let these chemicals come in contact with the colours on the covering and the plastic parts.

## HINGING THE AILERONS.

- 1) Carefully remove the aileron from one of the wing panels. Note the position of the hinges.
- 2) Remove each hinge from the wing panel and aileron and place a T-pin in the center of each hinge. Slide each hinge into the wing panel until the T-pin is snug against the wing panel. This will help ensure an equal amount of hinge is on either side of the hinge line when the aileron is mounted to the aileron.

**Note:** *The control surfaces, including the ailerons, elevators, and rudder, are prehinged with hinges installed, but the hinges are not glued in place. It is imperative that you properly adhere the hinges in place per the steps that follow using a high-quality thin C/A glue.*

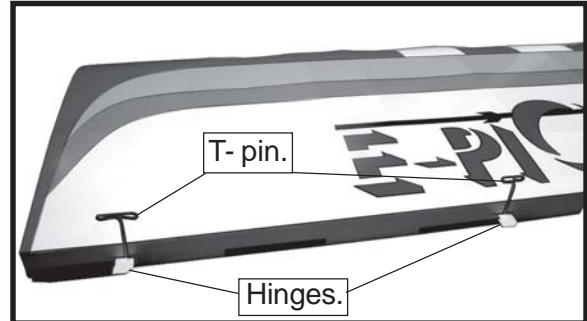

- 3) Slide the wing panel on the aileron until there is only a slight gap. The hinge is now centered on the wing panel and aileron. Remove the T-pins and snug the aileron against the wing panel. A gap of 1/64" or less should be maintained between the wing panel and aileron.

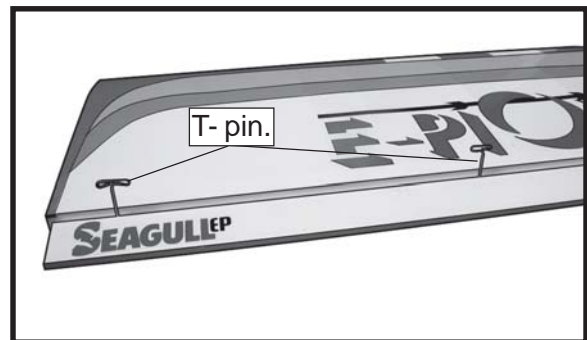

- 4) Deflect the aileron and completely saturate each hinge with thin C/A glue. The ailerons front surface should lightly contact the wing during this procedure. Ideally, when the hinges are glued in place, a 1/64" gap or less will be maintained throughout the length of the aileron to the wing panel hinge line.

**Note:** *The hinge is constructed of a special material that allows the C/A to wick or penetrate and distribute throughout the hinge, securely bonding it to the wood structure of the wing panel and aileron.*

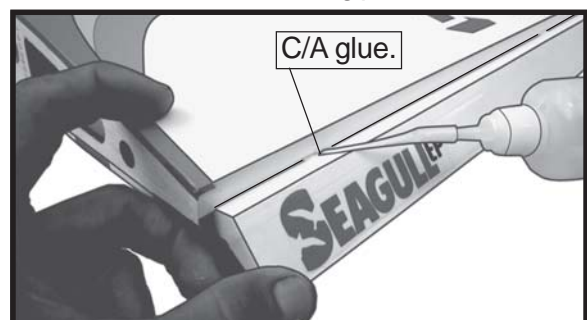

□ 5) Turn the wing panel over and deflect the aileron in the opposite direction from the opposite side. Apply thin C/A glue to each hinge, making sure that the C/A penetrates into both the aileron and wing panel.

□ 6) Using C/A remover/debonder and a paper towel, remove any excess C/A glue that may have accumulated on the wing or in the aileron hinge area.

□ 7) Repeat this process with the other wing panel, securely hinging the aileron in place.

□ 8) After both ailerons are securely hinged, firmly grasp the wing panel and aileron to make sure the hinges are securely glued and cannot be pulled out. Do this by carefully applying medium pressure, trying to separate the aileron from the wing panel. Use caution not to crush the wing structure.

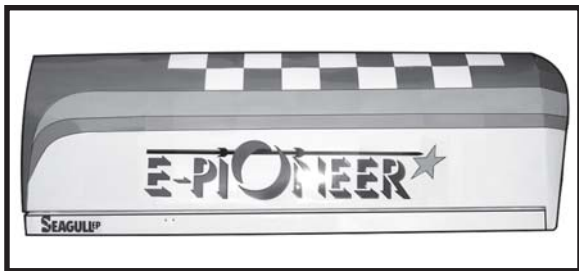

**Note:** Work the aileron up and down several times to “work in” the hinges and check for proper movement.

**HINGING THE ELEVATOR.**

Glue the elevator hinges in place using the same techniques used to hinge the ailerons.

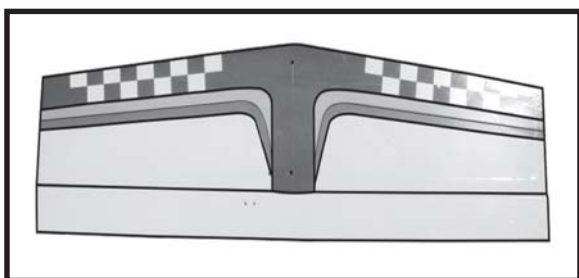

**HINGING THE RUDDER.**

Glue the rudder hinges in place using the same techniques used to hinge the ailerons.

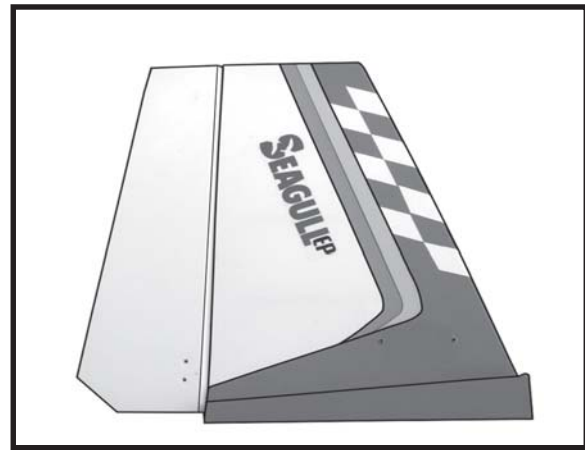

**INSTALLING ELECTRIC MOTOR.**

□ 1) Trial fit the motor on the firewall. The motor should be positioned so there is a ample clearance in the fuselage end side for the spinner backplate mounted to the propeller drive shaft.

□ 2) Marking four points on the firewall. Drill 4 pilots horn 4.5mm diameter.

□ 3) Insert 4 blind nuts at the back side of firewall. See picture below:

□ 4) There are 2 motor mounting boxes for your option. It is depended on the motor size.

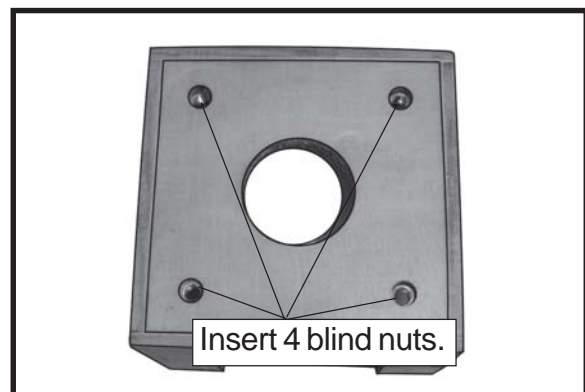

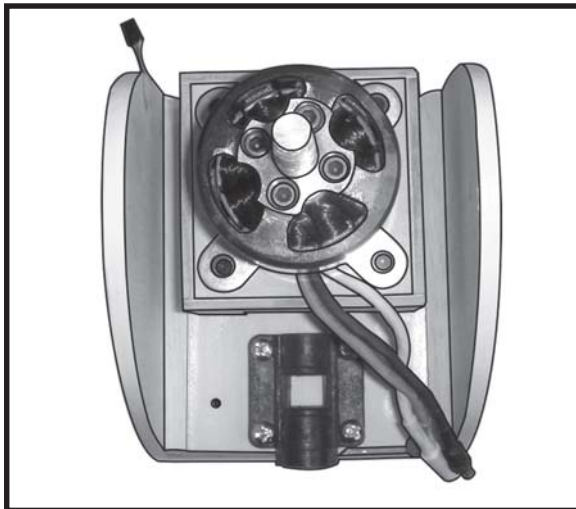
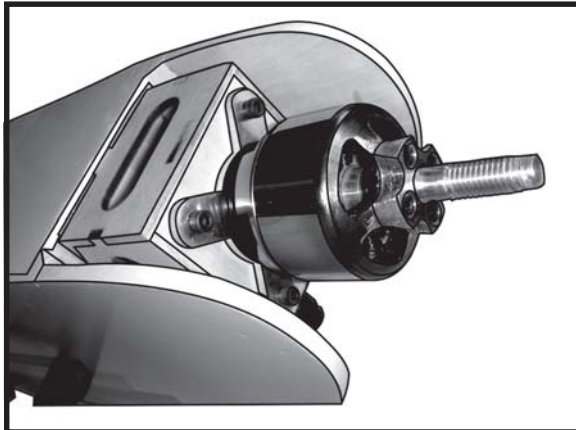
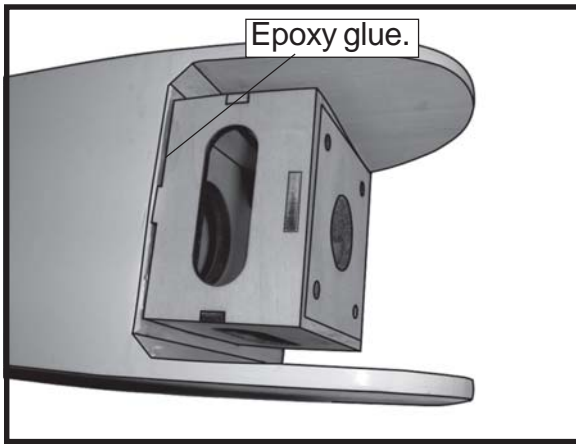

**PROPELLER INSTALLATION.**

 *The propeller should not touch any part of the fuselage side.*

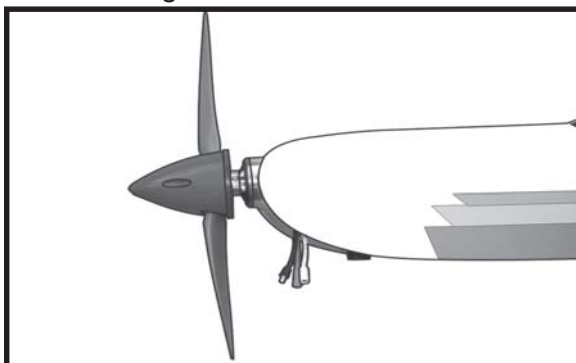

**NOSE GEAR INSTALLATION.**

1) Assemble the nose wheel as shown in the following pictures.

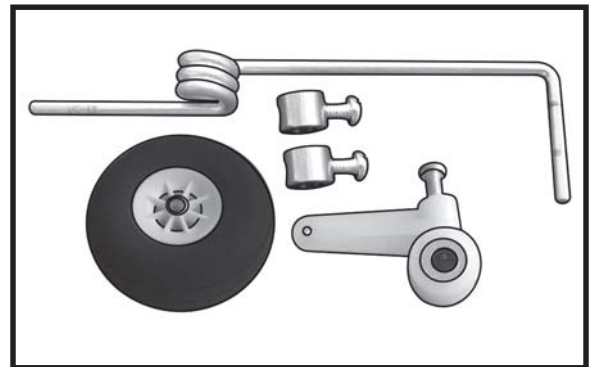

2) Mounting the nose gear as shown in the following pictures.

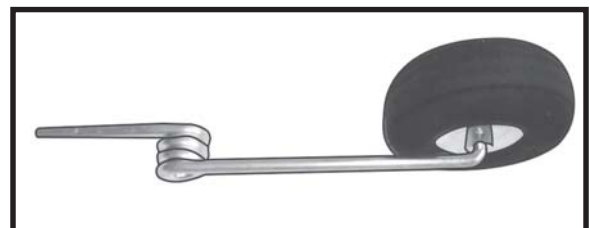

3) Adjust the nose gear steering arm until the arm is parallel with the firewall.

4) Install the pushrod wire as shown.

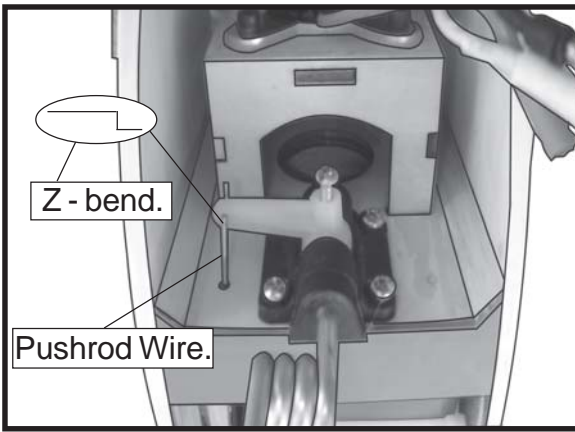

**INSTALLING THE BATTERY- NOSE GEAR SERVO .**

See pictures below.

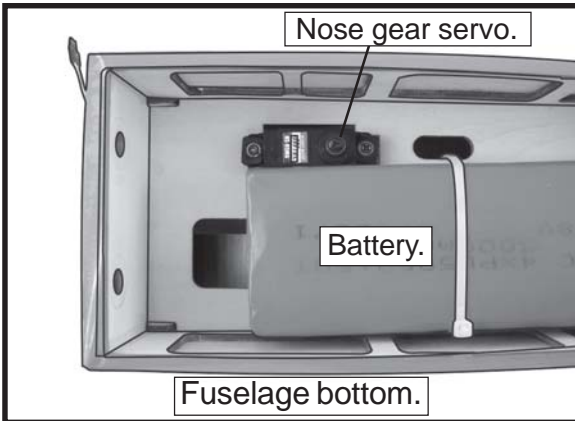
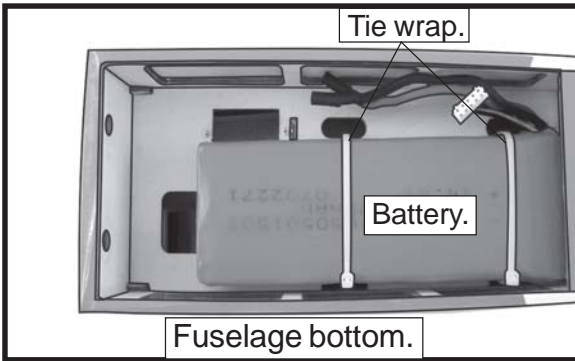

**INSTALLING THE STEERING ARM SERVO.**

Attach the micro control connector to the servo arms. Be sure to use the lock tie but it could free rotation .

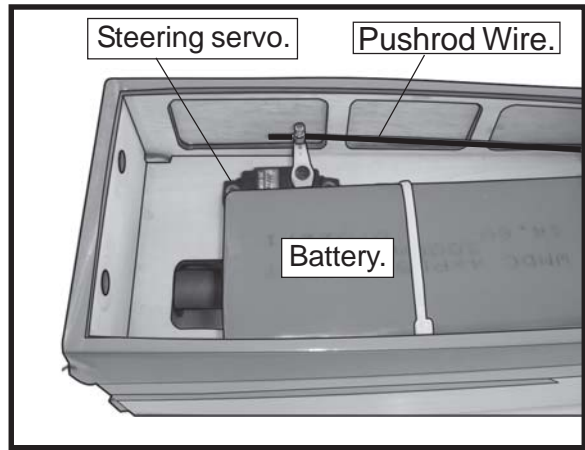
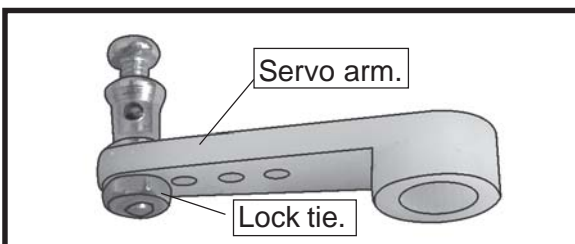

**INSTALLING THE MAIN WHEELS.**

Assemble and mounting the wheel as same as the way of nose wheel. See pictures below:

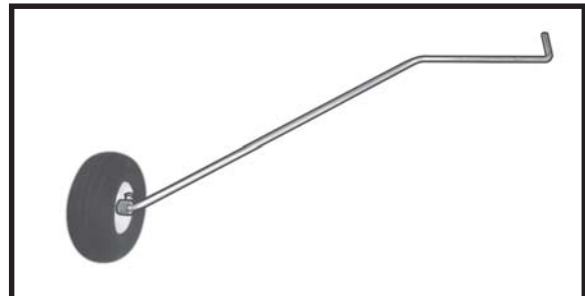
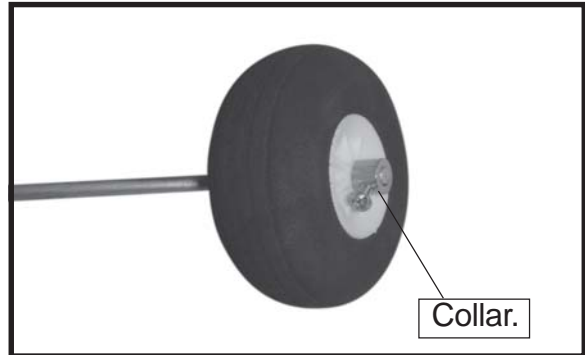

**INSTALLING THE MAIN LANDING GEAR.**

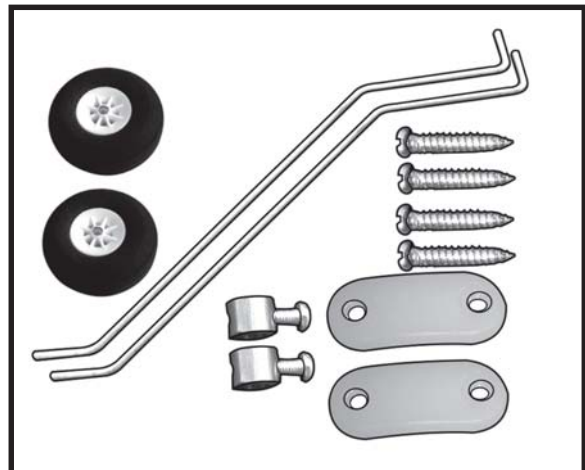

- 1) Using a modeling knife, remove the covering from over the main gear mounting slots located in the bottom of the fuselage.

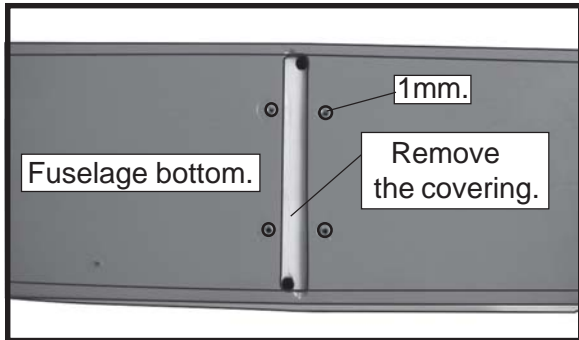

- 2) Insert the one main gear wire into the mounting slot. Using the hardware provided, mount the main landing gear to the fuselage.

- 3) The landing gear wire is held in place using two nylon landing gear straps and four 3mm x 10mm wood screws.

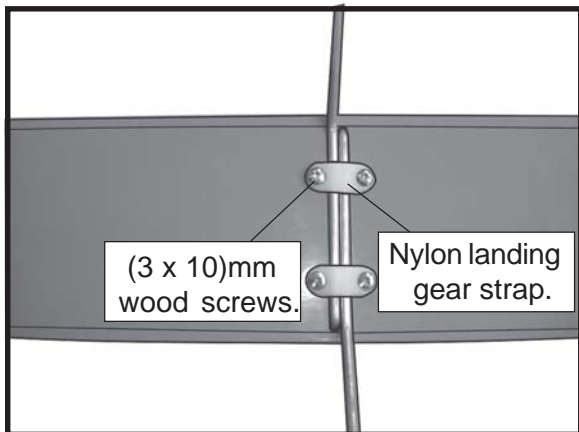

### AILERON SERVOS-LINKAGES.

- 1) Install the metal connector onto servo arm as same as picture below.

Attach the micro control connector to the servo arms. Be sure to use the lock tie but it could free rotation.

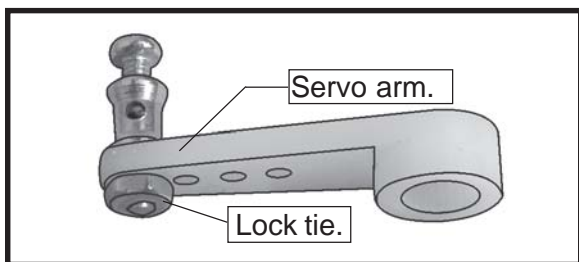

- 2) Turn the wing panel right side up. Using a modeling knife, remove the covering at servo tray.

Install the rubber grommets and brass collets onto the aileron servo. Test fit the servo into the aileron servo mount.

**!** *Because the size of servos differ, you may need to adjust the size of the precut opening in the mount. The notch in the sides of the mount allow the servo lead to pass through.*

Attach the thread to the servo lead and carefully thread it through the wing.

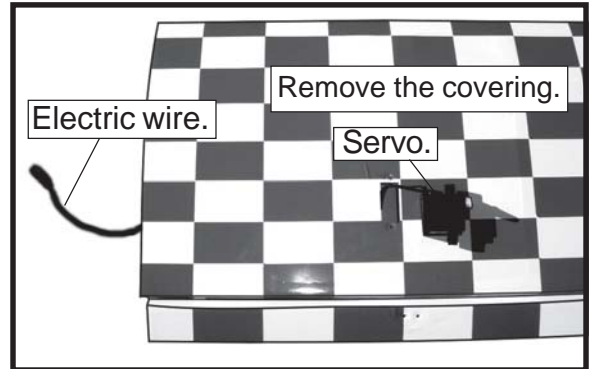

- 3) Secure the servo with the screws provided with your radio system.

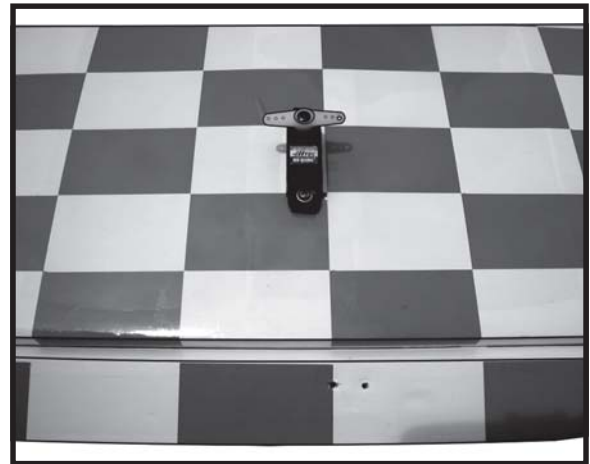

- 4) Insert aileron control horn to the aileron. as same as picture below.

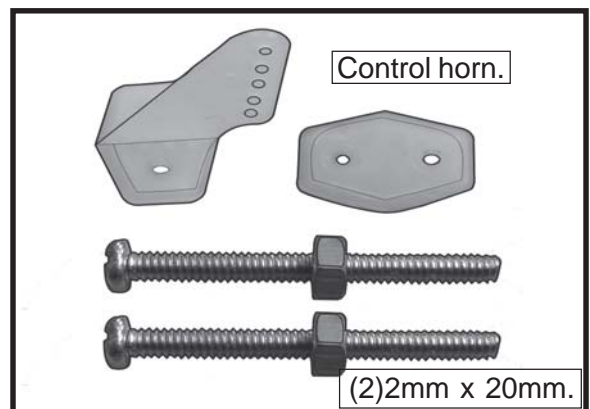

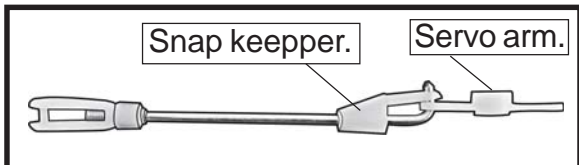
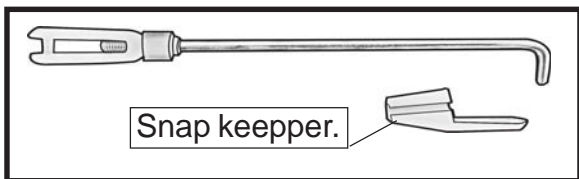
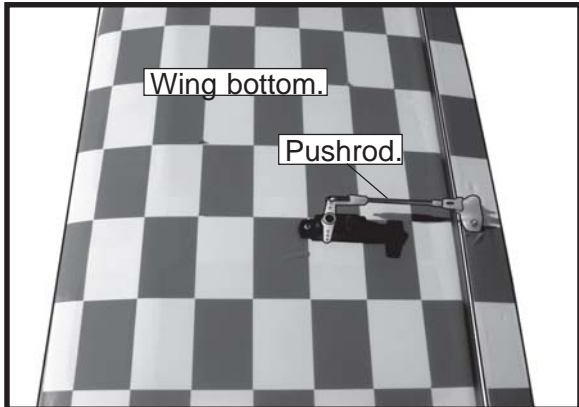
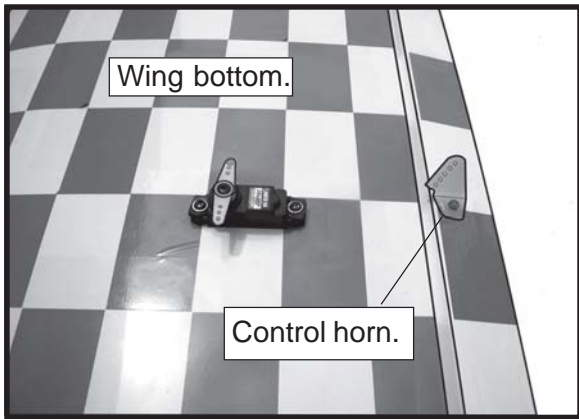

Repeat the procedure for orther wing haft.

**TAIL SERVOS-LINKAGES.**

Repeat the procedure as same as the wing .

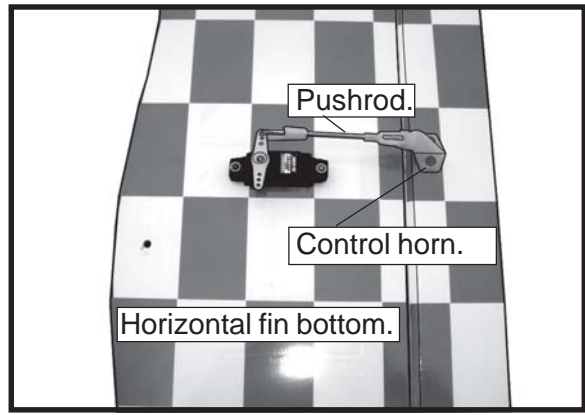
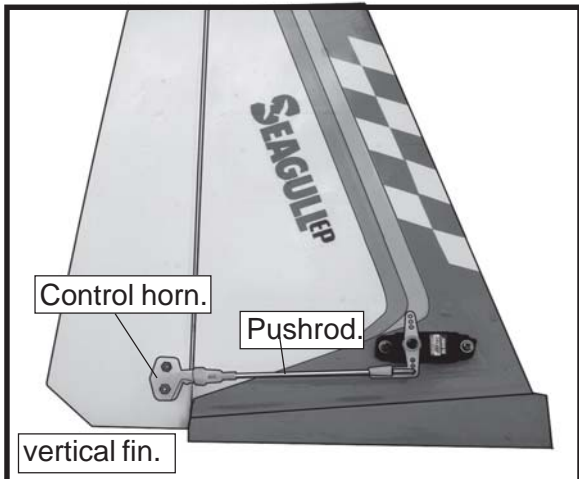

**ASSEMBLY THE TAIL FIN.**

See pictures below :

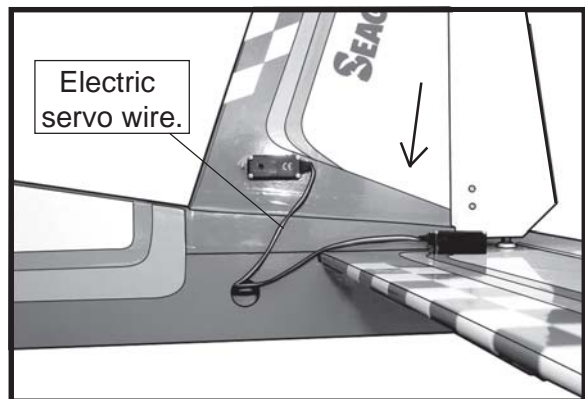
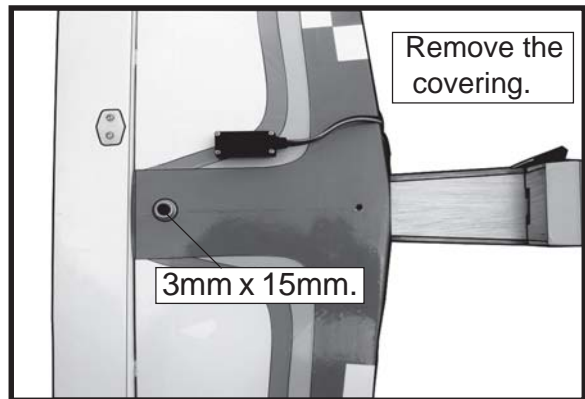
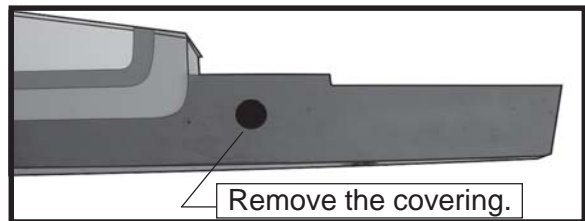
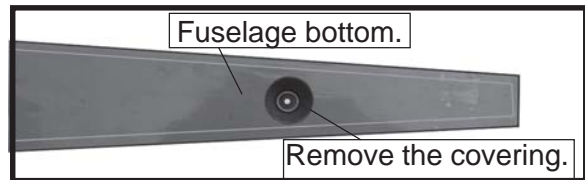

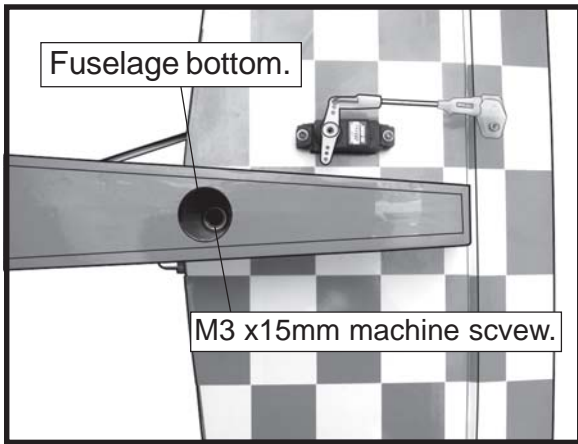

**INSTALLING THE FUSELAGE PARTS.**

See pictures below

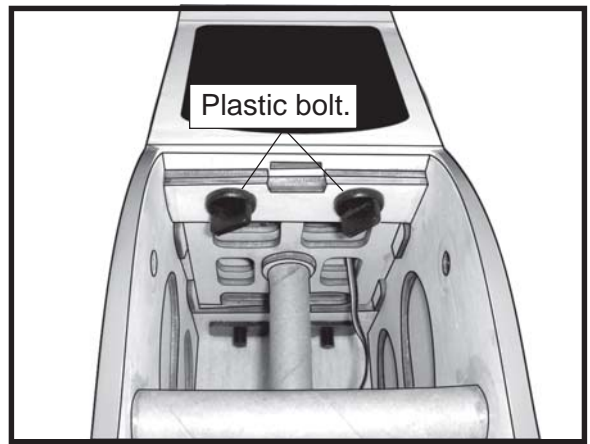
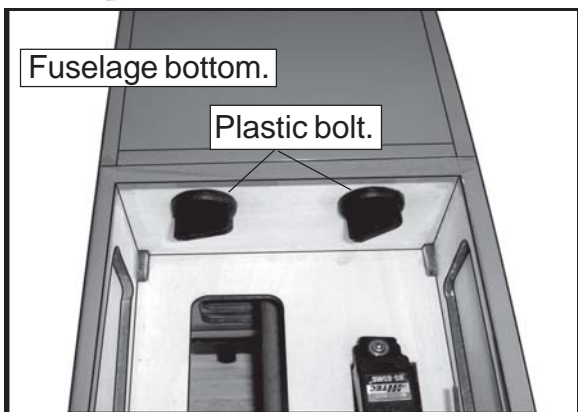
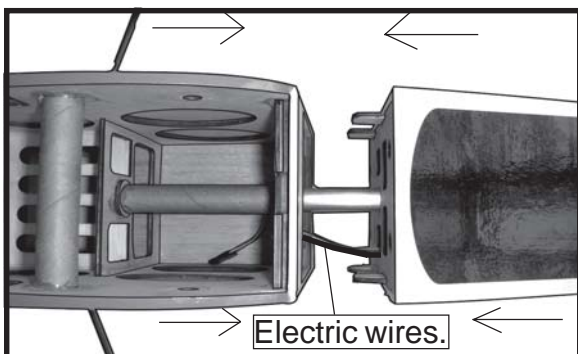
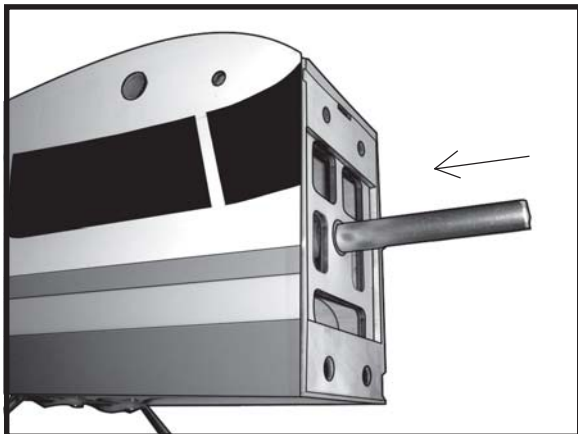
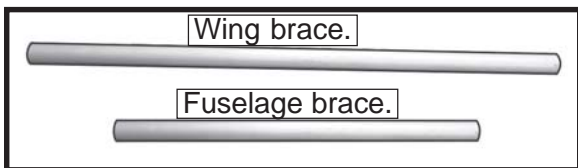

**INSTALLING THE RECEIVER.**

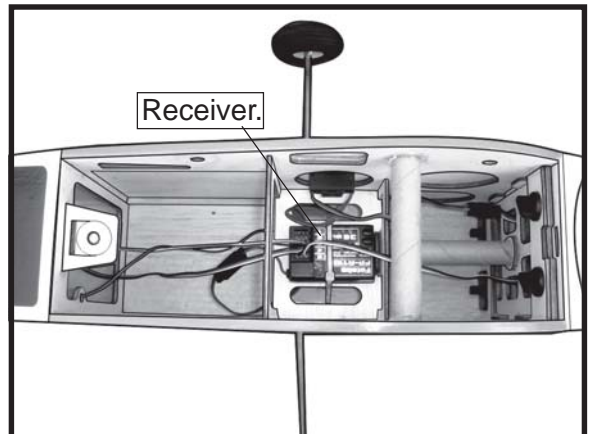

**ATTACHMENT WING-FUSELAGE.**

Attach the aluminium tube into fuselage.

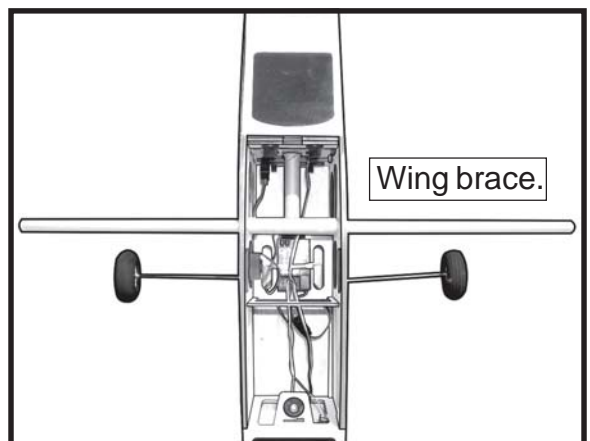
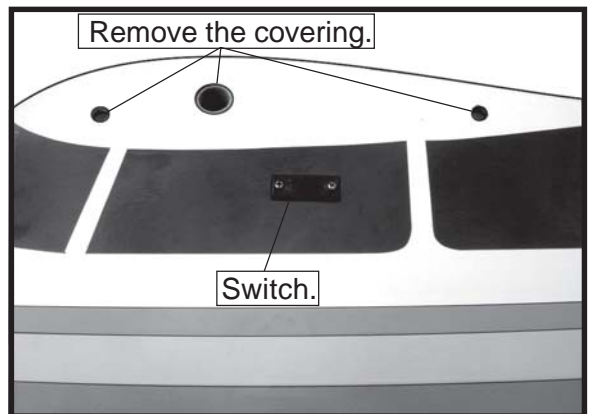

Insert two wing panels as pictures below:

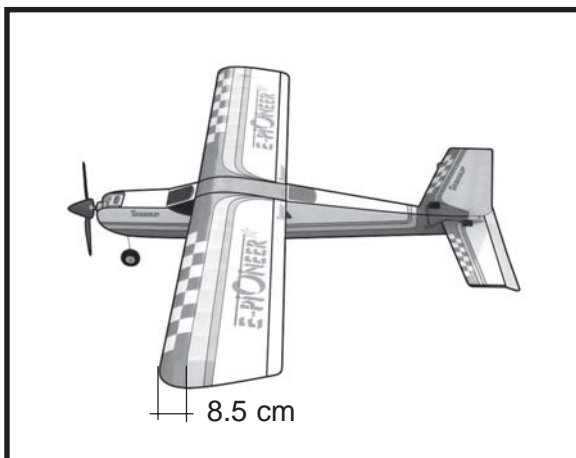
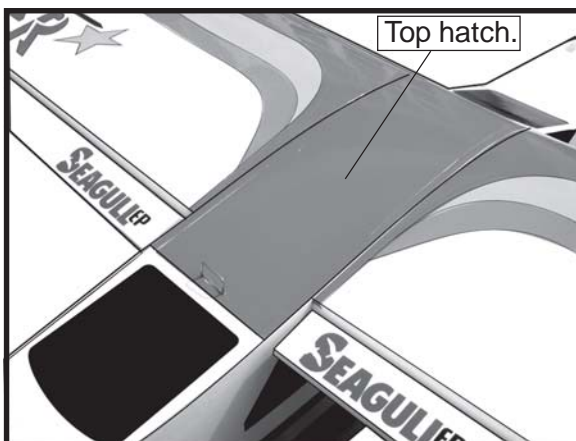
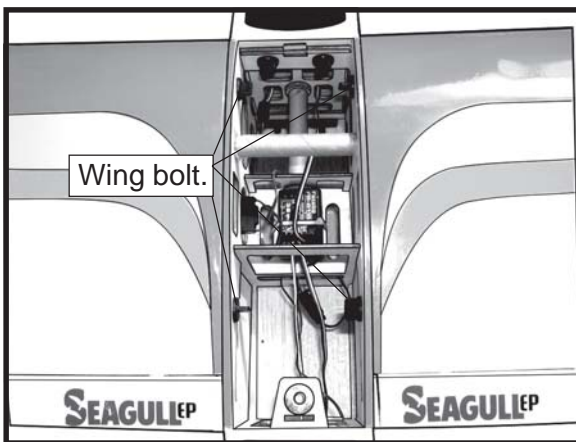
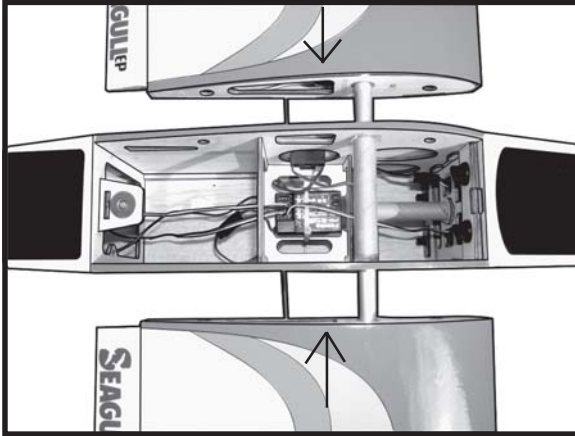

## BALANCING.

□1) It is critical that your airplane be balanced correctly. Improper balance will cause your plane to lose control and crash. The center of gravity is located **8.5cm** back from the leading edge of the wing, measured at wing tip.

□2) If the nose of the plane falls, the plane is nose heavy. To correct this first move the battery pack further back in the fuselage. If this is not possible or does not correct it, stick small amounts of lead weight on the fuselage sides under the horizontal stabilizer. If the tail of the plane falls, the plane is tail heavy. To correct this, move the battery and receiver forward or if this is not possible, stick weight onto the firewall. When balanced correctly, the airplane should sit level or slightly nose down when you lift it up with your fingers.

## CONTROL THROWS.

□1) We highly recommend setting up the E-PIONEER. using the control throws listed at right. We have listed control throws for both Low Rate (initial test flying/sport flying) and High Rate (aerobatic flying).

□2) Turn on the radio system, and with the trim tabs on the transmitter in neutral, center the control surfaces by making adjustments to the clevises or adjustable servo connectors. The servo arms should be centered also.

□3) When the elevator, rudder and aileron control surfaces are centered, use a ruler and check the amount of the control throw in each surface. **The control throws should be measured at the widest point of each surface!**

### INITIAL FLYING/SPORT FLYING

Ailerons:	3/8" up	3/8" down
Elevator:	3/8" up	3/8" down
Rudder:	1/2" right	1/2" left

### AEROBATIC FLYING

Ailerons:	1/2" up	1/2" down
Elevator:	5/8" up	5/8" down
Rudder:	1" right	1" left

***Do not use the aerobatic settings for initial test flying or sport flying.***

4) By moving the position of the adjustable control horn out from the control surface, you will decrease the amount of throw of that control surface. Moving the adjustable control horn toward the control surface will increase the amount of throw.

### **PREFLIGHT CHECK.**

A) Check the operation and direction of the elevator, rudder, ailerons and throttle.

B) Plug in your radio system per the manufacturer's instructions and turn everything on.

C) Check the elevator first. Pull back on the elevator stick. The elevator halves should move up. If it they do not, flip the servo reversing switch on your transmitter to change the direction.

D) Check the rudder. Looking from behind the airplane, move the rudder stick to the right. The rudder should move to the right. If it does not, flip the servo reversing switch on your transmitter to change the direction.

E) Check the throttle.

F) From behind the airplane, look at the aileron on the right wing half. Move the aileron stick to the right. The right aileron should move up and the other aileron should move down. If it does not, flip the servo reversing switch on your transmitter to change the direction.

### **FLIGHT PREPARATION.**

1) Completely charge your transmitter and receiver batteries before your first day of flying.

2) Check every bolt and every glue joint in the **PIONEER** to ensure that everything is tight and well bonded.

3) Double check the balance of the airplane. Do this with the fuel tank empty.

4) Check the control surfaces. All should move in the correct direction and not bind in any way.

5) If your radio transmitter is equipped with dual rate switches double check that they are on the low rate setting for your first few flights.

6) Check to ensure the control surfaces are moving the proper amount for both low and high rate settings.

7) Check the receiver antenna. It should be fully extended and not coiled up inside the fuselage.

8) Properly balance the propeller. An out of balance propeller will cause excessive vibration which could lead to engine and/or airframe failure.

***We wish you many safe and enjoyable flights with your PIONEER.***