

Manual

33611 General Air-Module 2-6 S with Vario Graupner HoTT 2.4

CONTENTS:

1. Description	01
2. Mounting the module n the plane	01
3. Connection of sensors	02
4. Starting up	03
5. Operation	03
5.1. Display LIPO CELL VOLTAGE	04
5.2. Sensor 1/2 voltage.....	05
5.3. Sensor 1/2 temperature.....	05
5.4. Vario display	06
5.5. REV counter	06
6. Programming warning thresholds	07
6.1. Minimum cell voltage (Page 2)).....	08
6.2. Minimum cell voltage sensor 1 (Page 3)	09
6.3. Maximum cell voltage sensor 1 (Page 4)	09
6.4. Minimum temperature sensor 1 (Page 5).....	09
6.5. Maximum temperature sensor 1 (Page 6).....	09
6.6. Minimum cell voltage sensor 2 (Page 7)	10
6.7. Maximum cell voltage sensor 2 (Page 8)	10
6.8. Minimum temperature sensor 2 (Page 9).....	10
6.9. Maximum temperature sensor 2 (Page 10).....	10
6.10. Maximum current (Page 11).....	11
6.11. Maximum capacity (Page 12).....	11
6.12. Minimum voltage socket 1 (Page 13).....	11
6.13. Maximum voltage socket 1 (Page 14).....	11
6.14. Minimum altitude (Page 15).....	12
6.15. Maximum altitude (Page 16).....	12
6.16. Sink rate per sec. (Page 17).....	12
6.17. Sink rate per 3 sec. (Page 18).....	12
6.18. Climb rate per sec. (Page 19).....	13
6.19. Climb rate per 3 sec. (Page 20).....	13
6.20. Minimum RPM (Page 21).....	13
6.21. Maximum RPM (Page 22).....	13
7. Setup-Displays	14
7.1. Calibration of temperature sensors	14
7.2. Continous Vario - sensitivity setup.....	15
7.3. Blade number	17
7.4. Current control.....	17
8. Summary signal tones	19
9. Telemetry display	20
10. Firmware-Update	21
11. Specifications	23

THANK YOU

for purchasing the General Air-Module for the Graupner HoTT 2.4 system.

If you do not have the Graupner HoTT 2.4 radio system this product will not work. This product is not compatible with any other 2.4GHz radio system.

Please read through this entire manual before you attempt the installation and usage of your Graupner HoTT General Air-Module!

These operating instructions are part of this product. They contains important notes to the operation and handling. Please take this into consideration when you pass on the product to third parties. Neglect of the operating instructions and the safety instructions lead to expiring the warranty.

Graupner constantly work on the advancement of all remote control systems; changes of the scope of delivery in form, technology and equipment we must reserve ourselves therefore. Please have understanding for the fact that from data and illustrations of this operating instructions no requirements can be derived.

Please keep these instructions for further reference!

1. DESCRIPTION

The Graupner-HoTT General Air-Module enables the wireless monitoring of for example the battery voltage, power consumption, motor rpm, fuel consumption or altitude of the model in real time. The General Air-Module can be programmed directly with all HoTT transmitters with integrated telemetry in the transmitter display (some models such as MC-24 with update or modification).

The following transmitters must be programmed via SMART-BOX order No. 33700: mx-12 HoTT order No. 4754, mx-16 HoTT order No. 4755, and mx-22 No. 4801/4802, mc-19 No. 4821 and mc-22 No. 4818 after conversion to HoTT. This differentiation between the transmitter models and the resulting operation is explicitly mentioned at the appropriate point in the instructions (see also point 5).

For full functionality, additional sensors are necessary.

Informations available - Setup:

Altitude, min. Altitude, max. Altitude, negative/positive difference/s, negative/positive difference/3s

Battery voltage (total - single cell), Min./Max. voltage, Min./Max. cell voltage

Maximum current, used capacity

Temperature (optional Sensor 1/Sensor 2), Min./Max. Temperature

Fuel level, Min. fuel level,

RPM, Minimum/ Maximum RPM

Note: Any settings you make on the Transmitter or SMART-BOX will be stored in the General Air-Module-only!

Since the General Air-Module can be updated via the USB connection, you always have the latest software and can utilize future functions or languages. Firmware updates for the General Air-Module can be transferred via the DATA or telemetry interface in conjunction with a PC running Windows XP, Vista or 7. For this you also require the USB interface, Order No. 7168.6, the adapter lead, Order No. 7168.6A and a Y-cable Order No. 3936.11 which are available separately.

The programs and files required for this are available from www.graupner.de in the Download area for the corresponding products.

2. MOUNTING THE MODULE IN THE PLANE

Mount the General Air-Module at an appropriate location in the model. The vario sensor is already integrated in the module. This sensor detects changes in air pressure and calculates the resulting actual altitude. Therefore, make sure that the sensor is wind-protected in the model and is not located directly in the flow of the propeller. Likewise, it must not be mounted on an air-tight place, such in a sealed radio box. The best way to fix the General Air-Module with the mounting tabs or double sided tape on a wind-protected frame in the model, the orientation of the sensor is not important.

Note: the accuracy of the sensor also varies with alterations in ambient air pressure, e.g. due to sudden changes in weather conditions, as well as with changes in air pressure which occur in the course of the

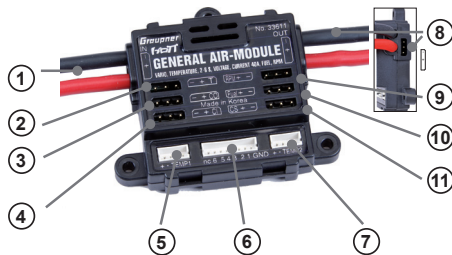

- ① Battery input max. 60 V DC / 40 A
- ② Receiver / SMART-BOX and Firmware-Update (T)
- ③ Control Out (output ESC)
- ④ Control In (input ESC)
- ⑤ Sensor 1 (33612 / 33613)
- ⑥ Balancer connector LiXX 2 - 6S
- ⑦ Sensor 2 (33612 / 33613)
- ⑧ Battery output
- ⑨ RPM sensor (33615 / 33616)
- ⑩ Fuel sensor (33614)
- ⑪ Control Switch (select switch for current control)

day or during an extended flight. It is not uncommon for minor fluctuations in air pressure to affect the accuracy of the sensor to the extent of about 10 to 20 m. These inaccuracies can also be caused by pressure changes inside the fuselage itself (e.g. high pressure due to the forced propeller airflow, or air flowing into the model during a flight).

3. CONNECTION OF SENSORS

The consumed current and capacity is measured only on connection 1 (IN) and 8 (OUT). Therefore, the main battery for the motor (electric model - G3.5 connector) or the transmitter battery (Nitro model - JR connector) must be connected to this connection. Use a connector system to replace the battery easily. If you use a LIXX battery, the balancer can be plugged into socket 6 to monitor the individual cell voltage.

Caution: never connect batteries to both sockets (G3.5 and JR)! These are inter-connected, and must only be used separately. Note also that the input voltage is present at the JR socket at output 8; do not connect the plug to the receiver if the voltage is higher than the maximum permissible voltage for receiver or servos.

Note: All negative terminals are interconnected and not galvanically separated.

Please ensure that the continuous current does not exceed the stated maximum for the current sensor. You should also ensure that the motor start-up current is not so high that the shunt resistors are overloaded! This can result in a break in the power supply, which would cause the model to crash.

For this reason it is important to carry out a thorough check of the motor's function and maximum current drain: start cautiously, then increase to maximum load and eventually to a full battery charge, to ensure that the current shunt resistors are not overloaded.

The "regulate current" function (see point 7.4.) can be used to limit the maximum current passing through the model's electronic speed controller. If the model's current drain is above the peak current permitted for the General Air module, then it is **essential** to use this function to prevent damage to the module or a break in the power supply.

If high peak currents are likely, you must use the more powerful General Electric sensor, Order No. 33620, or alternatively you might prefer to manage without current measurement altogether.

When measuring power system currents please note that the voltage fall-off at the shunt resistors can place an increased load on the speed controller, and on the speed controller's capacitors in particular. For safety reasons you should therefore operate the controller on one or two cells fewer than the maximum stated cell-count, i.e. not with the full count.

Connect any additional sensors to the corresponding sockets as shown in the illustration at the top.

4. STARTING UP

Connect the General Air-Module (socket 2) with the 3-pin lead to socket marked „T“ of the receiver. The connector system is polarised, look for the small camfer on the edges. Never use force - the plug should engage easily and fully. The sockets are labeled accordingly: black wire (-), red wire (+) and orange wire (S).

Only for transmitters under 1 „exception“ with SMART-BOX:

Install the SMART-BOX at the mounting bracket of the transmitter as shown in the figure. Connect the box then the 3-pin lead to the transmitter. Put one end of the cable into the DATA jack on the transmitter and the other into the jack on the right side of the SMART-BOX. The connector system is polarised, look for the small camfer on the edges. Never use force - the plug should engage easily and fully. The sockets are labeled accordingly: black wire (-), red wire (+) and orange wire (S).

Note: You can connect the General Air-Module instead of the receiver directly to the jack on the right side of the SMART-BOX. By doing this, the settings will be sent directly to the General Air-Module (without using the radio control system) and the programming is much faster. A power supply for the SMART-BOX is necessarily (3.6 - 9 V), inserted on the left side. The connector system is reverse polarised, look for the small camfer on the edges. Do not use force, the plug should click into place easily. This sockets is labeled accordingly also. The black wire must be down (-), the red top (+).

5. OPERATION

The operation of the General Air-Module is similar to the operation of the transmitter. You should also read the manual of your remote control system, especially the chapter „telemetry“. The operation is done in the transmitter menu „telemetry“ under the display SETTING & DATA VIEW. The sensor displays follow the receiver displays (RX), i.e. the „Lipo Cell Voltage“ display follows after the last display servo test (RX SERVO TEST). **Please note:** the menus can only be selected when the receiver is switched on. When you switch the receiver on, it may take a few seconds before the receiver display becomes active and can be selected: > symbol appears at the top right corner of the transmitter display (TX).

There may be a slight delay in the screen's response to inputs, since all the settings are transmitted directly to the receiver by wireless means.

Operation with the SMART-BOX:

The SMART-BOX is operated by the four buttons on the top. Switch with the ESC and ENTER keys between the different displays. With the DEC and INC buttons you can select the parameters in the display (INC moves the cursor down, DEC up).

Switch on the transmitter. On the startup screen appears SETTING AND DATA VIEW / MODEL SELECT. Move the arrow cursor with the INC or DEC buttons on SETTING AND DATA VIEW and then press ENTER to display the parameters of the transmitter, receiver and telemetry sensors and / or program it, or select MODEL SELECT to display the telemetry data graphically (see point 9). In MODEL SELECT display no changes are possible.

After SETTING AND DATA VIEW have chosen, the „Lipo Cell Voltage“ display is available. The sensor displays follow the transmitter (TX) and receiver (RX) displays, i.e. the „Lipo Cell Voltage“ display follows after the last display servo test (RX SERVO TEST).

Please note: the menus can only be selected when the receiver is switched on. When you switch the receiver on, it may take a few seconds before the receiver display becomes active and can be selected: > symbol appears at the top right corner of the transmitter display (TX).

There may be a slight delay in the screen's response to inputs using the top buttons, since all the settings are transmitted directly to the receiver by wireless means.

5.1. Display LIPO CELL VOLTAGE

Please note: the labeling of the arrows of the following displays corresponds to the keys on top of the SMART-BOX. This assignment is different depending on the remote control system.

SMART-BOX	mx-12/16/20/32 HoTT	mc-19/mc-22/mc-24/mx-24 HoTT
ENTER	▶	ENTER
ESC	◀	CLEAR
INC	scroll: ▼ value: ▲	scroll: push Rotary + ⤴ value: Rotary ⤵
DEC	scroll: ▲ value: ▼	scroll: push Rotary + ⤴ value: Rotary ⤵
INC+DEC	SET	push Rotary

The descriptive text describes also primarily the button layout and operation of the SMART-BOX, followed by the buttons of the mx-16 HoTT as an example in parentheses. Please note that the button layout for example of the HoTT mc-transmitters (order No. 4758, 4759) may differ. Read the manual of your remote control system to become familiar with the telemetry operation.

Parameter	Description	Setup
Overall Volt	Current voltage of the battery connected to socket 6	-
Min.	Minimum voltage of the battery connected to socket 6 since the start	-
Max.	Maximum voltage of the battery connected to socket 6 since the start	-
1N - 6N	Single cell voltage of the LiXX-battery connected to socket 6	-
Min.	Minimum single cell voltage of the LiXX-battery connected to socket 6 since the start	-
Max	Maximum single cell voltage of the LiXX-battery connected to socket 6 since the start	-

The displays 5.1 to 5.5 are simple data displays, this parameters can not be programmed.

Parameters which have different options in the Settings column of the table can be adjusted. If there are no options, the screen simply displays the parameter data.

Parameter	Description	Setup
Overall Volt	Current voltage of the battery connected to socket 6	-
Min.	Minimum voltage of the battery connected to socket 6 since the start	-
Max.	Maximum voltage of the battery connected to socket 6 since the start	-
1N - 6N	Single cell voltage of the LiXX-battery connected to socket 6	-
Min.	Minimum single cell voltage of the LiXX-battery connected to socket 6 since the start	-
Max	Maximum single cell voltage of the LiXX-battery connected to socket 6 since the start	-

5.2 Sensor 1/2 voltage

DEC		INC
Sensor 1 :	14.92V	
Min 11.53V	Max 16.800V	
Sensor 2 :	7.49V	
Min 5.60V	Max 8.40V	
Current :	30.2 A	
Max Current :	40.3 A	
Capacity :	2345 mA	
Voltage :	33.88V	

Parameter	Description	Setup
Sensor 1	Current voltage of sensor 1 connected to socket 5	-
Min./Max.	Minimum/Maximum voltage of sensor 1 connected to socket 5 since the start	-
Sensor 2	Current voltage of sensor 2 connected to socket 7	-
Min./Max.	Minimum/Maximum voltage of sensor 2 connected to socket 7 since the start	-
Current	Current of the battery connected to socket 1	-
Max. Current	Maximum current of the battery connected to socket 1 since the start	-
Capacity	Used capacity of the battery connected to socket 1 since the start	-
Voltage	Current voltage of the battery connected to socket 1	-

5.3. Sensor 1/2 Temperature

DEC		INC
Sensor 1 :	25°C	
Min 20°C	Max : 60°C	
Sensor 2 :	160°C	
Min 20°C	Max : 260°C	

Parameter	Description	Setup
Sensor 1	Current temperature of sensor 1 connected to socket 5	-
Min./Max.	Minimum/Maximum temperature of sensor 1 connected to socket 5 since the start	-
Sensor 2	Current temperature of sensor 2 connected to socket 7	-
Min./Max.	Minimum/Maximum temperature of sensor 2 connected to socket 7 since the start	-

5.4. Vario Display

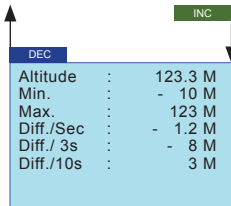

Note: The VARIO MODULE is set to the level 0 m after switching on. The altitude displayed is not the absolute altitude above sea level, but the relative height from the base!

In the first row the climb-/sink rate in meter per second is displayed on demand in synchronization with the warning tones alternating with „Vario sensor“, the vertical speed in meters per second. Sinking is represented by the negative sign.

Parameter	Description	Setup
Altitude	Current Altitude (Meter)	-
Min.	Minimum Altitude since the start (Meter)	-
Max.	Maximum Altitude since the start (Meter)	-
Diff. / Sec	Climb-Sink rate (Meter per sec.) - sinking is displayed with neg. sign	-
Diff. / 3s	Climb-Sink rate (Meter per 3 sec.) - sinking is displayed with neg. sign	-
Diff. / 10s	Climb-Sink rate (Meter per 10 sec.) - sinking is displayed with neg. sign	-

5.5. Rev counter

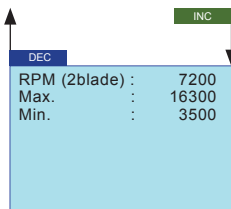

With connected speed sensor, the current engine rpm is determined. Therefore, you must first specify how many blades (or magnets with sensor order no. 33516) the propeller / rotor has to get the correct rpm. In addition, you can set the minimum engine speed at which the alarm should be triggered. See point 7.3. for setup.

Parameter	Description	Setup
RPM (2 blade)	Current motor speed in revolutions per minute and the preset blade number	-
Max.	Maximum RPM since the start	-
Min.	Minimum RPM since the start	-

6. PROGRAMMING WARNING THRESHOLDS

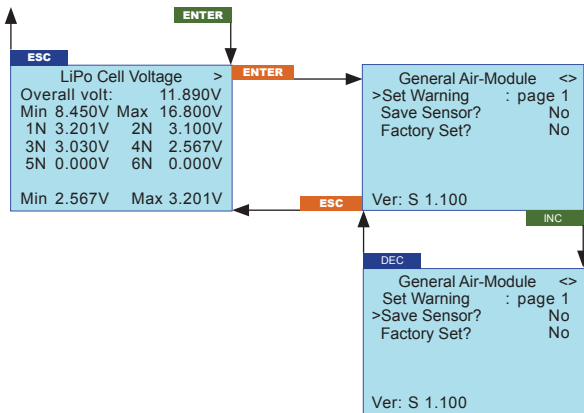

If you wish to carry out an adjustment, you must use the INC or DEC buttons (▲ or ▼) above the screen to select the desired parameter (e.g. page 2) by moving the arrow cursor (INC or ▼ moves the cursor down, DEC oder ▲ moves it up). Simultaneously pressing the INC and DEC (**SET**) buttons switches the parameter to be adjusted to inverse video (white on black); this indicates that it can be programmed: pressing the INC (▲) button at this point increases the value, pressing the DEC (▼) button reduces the value. When the adjustment is complete, save the selected setting by pressing the INC and DEC (**SET**) buttons simultaneously; the dark background now disappears in order to confirm this action.

Display (Set Warning): shows the various „display pages“ with the possible adjustable parameters and the associated adjustable warning thresholds (page 1, page 2, etc.). To switch between pages, press the INC or DEC key (▲ or ▼).

Factory Set: choosing „YES“, will reset the settings of the variable module to factory settings.

The following parameters can be set separately for all displays:

Warning Time: sets whether and how long the warning signal is activated when reaching a certain value for each display screen.

Repeat Time: sets how often the warning signal is activated when reaching a certain value for each display screen.

Signal Tone: sets the signal tone melody. The warning sounds are combined with the warnings on the display and the voice output. Therefore, they may not be changed.

Overview of the signal tones on page 18.

When a warning is activated, the corresponding message (eg. Min. Height) is shown inverted in the first row of the associated display, which then appears alternately with the display VARIO SENSOR and the selected Signal Tone A - Z sounds.

You can stop the warning at any time by pressing one of the buttons on the top of the SMART-BOX.

Parameter	Display page	Description	Setup
Warning Time	Page 2 – page 24	Warning time	OFF, 5, 10, 15, 20, 25, 30 sec.
Repeat Time	Page 2 – page 24	Repeat time	Always, 1, 2, 3, 4, 5 Minuten, One Time
Signal Tone	Page 2 – page 24	Signal tone	A - Z
Save Sensor	Page 1	saves the setup to the General Air-Module	YES / NO
Factory Set	Page 1	Reset to factory settings	YES / NO

If you wish to carry out an adjustment (point 6.1 to 6.21) you must use the INC (▲) or DEC (▼) buttons above the screen to select „page 1 - Save Sensor“. Simultaneously pressing the INC and DEC buttons (SET) switches the parameter to be adjusted to inverse video (white on black); this indicates that it can be programmed: pressing the INC (▲) button at this point increases the value to YES. When the adjustment is complete, save the selected setting by pressing the INC and DEC buttons (SET) simultaneously; the dark background now disappears in order to confirm this action.

If you do not want to save the adjustments, select NO.

Warning:

- Do not carry out any programming work on the sensors while the model is flying, otherwise there is a real risk that your model will fly out of control while you are not concentrating on it!
- If your model is fitted with two or more receivers, it is absolutely essential that you do not carry out programming work during a flight, as this can alter the settings in the receivers to which no telemetry equipment is connected; in the worst case this could result in the model crashing.

For this reason always carry out programming on the ground, and check that only the receiver with connected sensors is powered on.

6.1. Minimum Cell Voltage (Page 2)

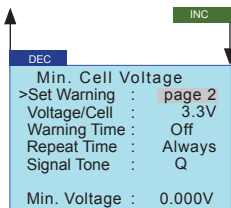

The voltage of the battery connected to socket 6 is monitored. Warning threshold set between 2.5 and 4.2 V (0.1 V steps).

Factory setting: 3.3 V, Signal Tone: Q

The bottom line shows the current measured value.

6.2. Minimum Cell Voltage Sensor 1 (Page 3)

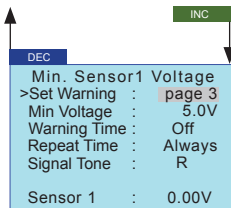

Min. Sensor1 Voltage
>Set Warning : page 3
Min Voltage : 5.0V
Warning Time : Off
Repeat Time : Always
Signal Tone : R
Sensor 1 : 0.00V

The voltage of the battery connected to sensor 1 (socket 5) is monitored. Warning threshold set between 0 and 80.0 V (0.1 V steps).
Factory setting: 5.0 V, Signal Tone: R

6.3. Maximum Cell Voltage Sensor 1 (Page 4)

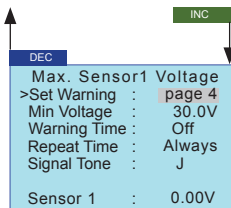

Max. Sensor1 Voltage
>Set Warning : page 4
Min Voltage : 30.0V
Warning Time : Off
Repeat Time : Always
Signal Tone : J
Sensor 1 : 0.00V

The voltage of the battery connected to sensor 1 (socket 5) is monitored. Warning threshold set between 0 and 80.0 V (0.1 V steps).
Factory setting: 30.0 V, Signal Tone: J

6.4. Minimum Temperature Sensor 1 (Page 5)

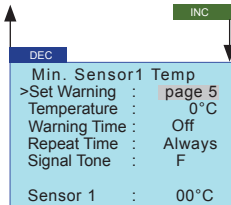

Min. Sensor1 Temp
>Set Warning : page 5
Temperature : 0°C
Warning Time : Off
Repeat Time : Always
Signal Tone : F
Sensor 1 : 00°C

The temperature of the sensor 1 (socket 5) is monitored. Warning threshold set between -20 and 200° C (1° C steps).
Factory setting: 0° C, Signal Tone: F

6.5. Maximum Temperatur Sensor 1 (Page 6)

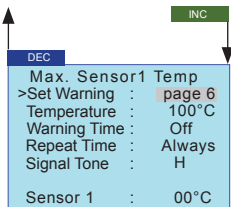

Max. Sensor1 Temp
>Set Warning : page 6
Temperature : 100°C
Warning Time : Off
Repeat Time : Always
Signal Tone : H
Sensor 1 : 00°C

The temperature of the sensor 1 (socket 5) is monitored. Warning threshold set between -20 and 200° C (1° C steps).
Factory setting: 100° C, Signal Tone: H

6.6. Minimum Cell Voltage Sensor 2 (Page 7)



Min. Sensor2 Voltage	
>Set Warning :	page 7
Min Voltage :	5.0V
Warning Time :	Off
Repeat Time :	Always
Signal Tone :	S
Sensor 2 :	0.00V

The voltage of the battery connected to sensor 2 (socket 7) is monitored. Warning threshold set between 0 and 80.0 V (0.1 V steps).
Factory setting: 5.0 V, Signal Tone: S

6.7. Maximum Cell Voltage Sensor 2 (Page 8)



Max. Sensor2 Voltage	
>Set Warning :	page 8
Max Voltage :	30.0V
Warning Time :	Off
Repeat Time :	Always
Signal Tone :	K
Sensor 2 :	0.00V

The voltage of the battery connected to sensor 2 (socket 7) is monitored. Warning threshold set between 0 and 80.0 V (0.1 V steps).
Factory setting: 30.0 V, Signal Tone: K

6.8. Minimum Temperature Sensor 2 (Page 9)



Min. Sensor2 Temp	
>Set Warning :	page 9
Temperature :	0°C
Warning Time :	Off
Repeat Time :	Always
Signal Tone :	G
Sensor 2 :	00°C

The temperature of the sensor 2 (socket 7) is monitored. Warning threshold set between -20 and 200° C (1° C steps).
Factory setting: 0° C, Signal Tone: G

6.9. Maximum Temperature Sensor 2 (Page 10)



Max. Sensor2 Temp	
>Set Warning :	page 10
Temperature :	100°C
Warning Time :	Off
Repeat Time :	Always
Signal Tone :	I
Sensor 2 :	00°C

The temperature of the sensor 2 (socket 7) is monitored. Warning threshold set between -20 and 200° C (1° C steps).
Factory setting: 100° C, Signal Tone: I

6.10. Maximum Current (Page 11)

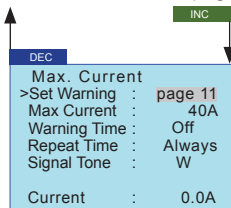

DEC	INC
Max. Current	
>Set Warning	: page 11
Max Current	: 40A
Warning Time	: Off
Repeat Time	: Always
Signal Tone	: W
Current	: 0.0A

If the module is connected between the power supply and the motor or receiver battery, the power consumption of the connected equipment is measured. You can program the maximum peak current at which the alarm should be triggered, to avoid to overload the motor or battery.

Monitors the battery connected to port 1. The warning threshold is adjustable up to 50 A in 0.1 A steps.

Factory setting: 40 A, Signal Tone: W

6.11. Maximum used Capacity (Page 12)

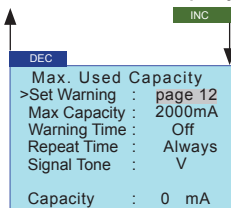

DEC	INC
Max. Used Capacity	
>Set Warning	: page 12
Max Capacity	: 2000mA
Warning Time	: Off
Repeat Time	: Always
Signal Tone	: V
Capacity	: 0 mA

If the module is connected between the power supply and the motor or receiver battery, the power consumption of the connected equipment is measured. You can program the max. used capacity at which the alarm should be triggered, so you have enough remaining capacity for a safe landing.

Monitors the battery connected to port 1. The warning threshold is adjustable up to 30.000 mAh in 0.1 A steps.

Factory setting: 2000 mAh, Signal Tone: V

6.12. Minimum Voltage socket 1 (Page 13)

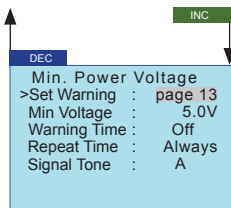

DEC	INC
Min. Power Voltage	
>Set Warning	: page 13
Min Voltage	: 5.0V
Warning Time	: Off
Repeat Time	: Always
Signal Tone	: A

The voltage of the battery connected to socket 1 is monitored. Warning threshold set between 0 and 80.0 V (0.1 V steps).

Factory setting: 5.0 V, Signal Tone: P

6.13. Maximum Voltage socket 1 (Page 14)

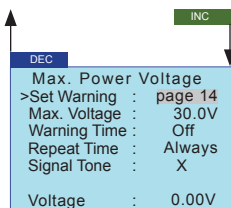

DEC	INC
Max. Power Voltage	
>Set Warning	: page 14
Max. Voltage	: 30.0V
Warning Time	: Off
Repeat Time	: Always
Signal Tone	: X
Voltage	: 0.00V

The voltage of the battery connected to socket 1 is monitored. Warning threshold set between 0 and 80.0 V (0.1 V steps).

Factory setting: 30.0 V, Signal Tone: X

6.14. Minimum Altitude (Page 15)

Min. Altitude	
>Set Warning	: page 15
Min. ALT	: 20m
Warning Time	: Off
Repeat Time	: Always
Signal Tone	: O
Altitude	: 0.0m

The Vario module is integrated into the General Air-Module, here you have no additional sensors.

Minimum altitude of the model during operation, warning threshold set between -500 and +3000 m in 1 m steps (based on the starting altitude 0 m)

Factory setting: 20 m, Signal Tone: O

6.15. Maximum Altitude (Page 16)

Max. Altitude	
>Set Warning	: page 16
Max. ALT	: 500m
Warning Time	: Off
Repeat Time	: Always
Signal Tone	: Z
Altitude	: 0.0m

The Vario module is integrated into the General Air-Module, here you have no additional sensors.

Maximum altitude of the model during operation, warning threshold set between -500 and +3000 m in 1 m steps (based on the starting altitude 0 m)

Factory setting: 500 m, Signal Tone: Z

6.16. Sink rate per second (Page 17)

Negative Difference 1	
>Set Warning	: page 17
Diff / Sec	: - 10 m
Warning Time	: Off
Repeat Time	: Always
Signal Tone	: C
Diff./Sec.	: 0.0m

The Vario module is integrated into the General Air-Module, here you have no additional sensors.

Sink rate/s (**Negative Difference 1**): Sink rate of the model per sec. in Meter, warning threshold set between -50 and 0 m (based on the starting altitude 0 m)

Factory setting: 10 m/Sec., Signal Tone: C

6.17. Sink rate per 3 seconds (Page 18)

Negative Difference 2	
>Set Warning	: page 18
Diff / 3 Sec	: - 1 m
Warning Time	: Off
Repeat Time	: Always
Signal Tone	: B
Diff./ 3Sec.	: 0.0m

The Vario module is integrated into the General Air-Module, here you have no additional sensors.

Sink rate/s (**Negative Difference 2**): Sink rate of the model per 3 sec. in Meter, warning threshold set between -500 and 0 m (based on the starting altitude 0 m)

Factory setting: 1 m/3 Sec., Signal Tone: B

6.18. Climb rate per second (Page 19)

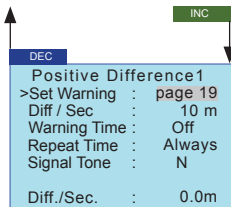

The Vario module is integrated into the General Air-Module, here you have no additional sensors.

Climb rate/s (**Positive Difference 1**): Climb rate of the model per sec. in Meter, warning threshold set between 0 and 50 m (based on the starting altitude 0 m)

Factory setting: 10 m/Sec., Signal Tone: N

6.19. Climb rate per 3 seconds (Page 20)

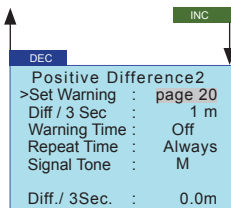

The Vario module is integrated into the General Air-Module, here you have no additional sensors.

Climb rate/3s (**Positive Difference 2**): Climb rate of the model per sec. in Meter, warning threshold set between 0 and 500 m (based on the starting altitude 0 m)

Factory setting: 1 m/3 Sec., Signal Tone: M

6.20. Minimum RPM (Page 21)

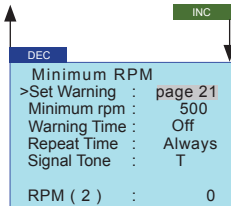

Monitors the optional speed sensor order no. 33615 or 33616 connected to socket 9.

With connected speed sensor, the current engine rpm is determined. Therefore, you must first specify how many blades the propeller / rotor has to get the correct rpm (see Section 7.3). In addition, you can set the minimum engine speed at which the alarm should be triggered.

Blade Number: adjustable from 1 to 6 blades

The warning threshold is adjustable from 0 to 200.000 rpm (1 blade) with 10 rpm steps.

Factory setting: 500 rpm, Signal Tone: T

6.21. Maximum RPM (Page 22)

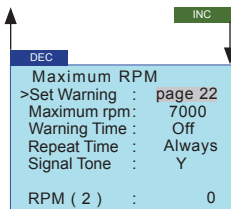

Monitors the optional speed sensor order no. 33615 or 33616 connected to socket 9.

The warning threshold is adjustable from 0 to 200.000 rpm (1 blade) with 10 rpm steps.

Factory setting: 7000 rpm, Signal Tone: Y

7. SETUP DISPLAYS

7.1. Calibration of the temperature sensors

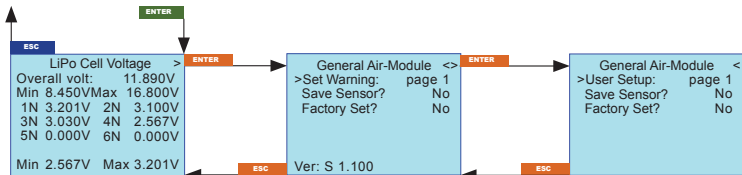

Go to the User Setup screen of the General Air-Module as in the diagram shown above. Select the User Setup display as shown in the diagram. Press the INC and DEC buttons on the SMART-BOX (resp. **SET**) simultaneously and select User Setup page 2. You can now calibrate the temperature of the sensors 1 and 2 in the range of -10 to +10 ° C to increase the accuracy of the display. To save the settings, go back to page 1 and choose ,Save Sensor, YES.

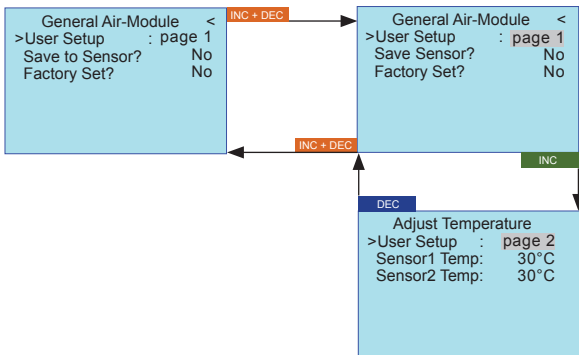

7.2. Continuous vario

The module provides two vario functions:

- 1. Continuous Vario:** is automatically launched when the menu telemetry VOICE TRIGGER, VARIO is a switch has been set and then the graphical display of the ELECTRIC AIR MODULE is activated. This function CONTINUOUS VARIO shows the climb or descent of the model permanently by rising or falling beeps.
- 2. Sensitivity Vario (only with the modules M-G1/M-G2, mx-12/16 order No. 4754/4755 or mc-19/22 HoTT 4758/4759) - output only through modules buzzer:** The climb or descent rate is predetermined by the parameter sensitivity (SENSITIVITY). The sensitivity must be programmed before operation. You can choose between: (OFF), 0.5 m / sec 3, 1 m / 3 s, 0.5 m / sec., 1 m / sec. or 3 m / sec. Factory setting is 1 m / sec. *You should use one of these at the same time.*

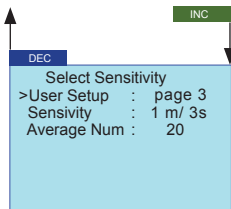

Sensitivity Setup

Select the User Setup display as shown in the diagram. Press the INC and DEC buttons on the SMART-BOX (resp. **SET**) simultaneously and select User Setup page 3. To save the selected settings, go back to page 1 and choose ,Save Sensor, YES.

Parameter	Description	Setup
User Setup	Setup page	1 - 2 (page)
Save to Sensor	Save the setup to the General Air-Module	YES / NO
Factory Set	Reset to factory settings	YES / NO
Sensitivity	Sensitivity - Continuous vario	OFF, 0.5m/3s; 1 m/3s; 0.5 m/s; 1m/s or 3.0 m/s Factory setting 1 m/s
Average Number	Number of measurements of the sensor per Sec.	4 - 40 Factory setting: 20

SENSITIVITY: select the climb or sink rate at which the BEEP is activated.

Climbing is indicated by a high tone, sinking by a deep tone. The higher / lower the tone sounds, the greater / smaller is the climb or sink rate.





Note: when SENSITIVITY is set to OFF, no beeps or voice announcements will be displayed.

See the following table.





If the setting is for example 1 m/sec., the tone (A) sounds when the model climbs more than 1 m per second. Is the rate more than 2 m, the next higher note (B) sounds, etc. The actual climb or descent rate is displayed in the Vario screen alternately in the top row. This display responds faster than the „Diff.“- information the display below, so the values can differ.

Climbing/sinking tone overview:

Climb rate:

5 m (E)		2.5 m/3 sec. ; 5 m/3 sec. 2.5 m/sec. ; 5 m/sec. ; 15 m/sec.
4 m (D)		2 m/3 sec. ; 4 m/3 sec. 2 m/sec. ; 4 m/sec. ; 12 m/sec.
3 m (C)		1.5 m/3 sec. ; 3 m/3 sec. 1.5 m/sec. ; 3m/sec.; 9 m/sec.
2 m (B)		1 m/3 sec. ; 2 m/3 sec. 1 m/sec. ; 2 m/sec. ; 6 m/sec.
1 m (A)		0.5 m/3 sec. ; 1 m/3 sec. 0.5 m/sec. ; 1 m/sec.; - 3 m/sec.

Sink rate:

- 1 m		- 0.5 m/3 sec. ; - 1 m/3 sec. - 0.5 m/sec. ; - 1 m/sec. ; - 3 m/sec.
- 2 m		- 1 m/3 sec. ; - 2 m/3 sec. - 1 m/sec. ; - 2 m/sec. ; - 6 m/sec.
- 3 m		- 1.5 m/3 sec. ; - 3 m/3 sec. - 1.5 m/sec. ; - 3m/sec. ; - 9 m/sec.
- 4 m		- 2 m/3 sec. ; - 4 m/3 sec. - 2 m/sec. ; - 4 m/sec. ; - 12 m/sec.
- 5 m		- 2.5 m/3 sec. ; - 5 m/3 sec. - 2.5 m/sec. ; - 5 m/sec. ; - 15 m/sec.

AVERAGE NUMBER: Number of measurements per second, is used to adjust the accuracy of the sensor. More measurements increase the accuracy, while fewer measurements increase display speed.

Recommendation:

Sensitivity 0.5 m: approx. 20 measurements per Sec.

Sensitivity 1 m: approx. 4 measurements per Sec.

Climbing or sinking according to the setting „Sensitivity“ in the User setup is displayed alternately on the top line in meter per sec., the associated melody also sounds. This display responds faster than the „Diff.“-information the display below, so the values can differ.

Altitude level Beep:

when the following altitudes (starting from the starting altitude 0 m) are reached, the following tones **will** sound:

20 / 40 / 60 / 80 / 100 m: low tone once (20 m) up to five times (100 m)

200 / 400 / 650 / 800 / 1000 m: high tone once (200 m) up to five times (1000 m)

7.3. Blade Number:

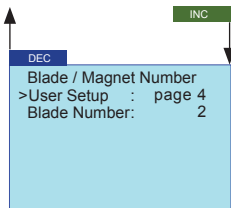

With connected speed sensor, the current engine rpm is determined. Therefore, you must first specify how many blades (or magnets with sensor order no. 33516) the propeller / rotor has to get the correct rpm. In addition, you can set the minimum engine speed at which the alarm should be triggered.

Blade Number: adjustable from 1 to 6 blades

7.4. Current Control:

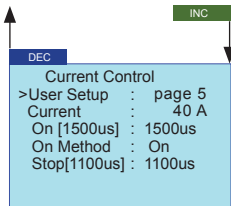

In this display you can determine and limit the maximum current drawn by the model's power system.

If the model's current drain is above the permitted peak current for the General Air module, it is essential to use this function to prevent damage to the module or a break in the power supply, as this would be likely to cause the model to crash (see also *Point 3: connecting the sensors*).

Parameter	Description	Setup
Current	Maximum current	0 - 60 A
On [XXXXus]	Current control activated	500 - 2500 us
On Method	Current control enabled , is the current consumption above the CURRENT value, the ESC goes to STOP position until the current consumption drops again Current control disabled , IN signal CI is outputted as CO without modification	ON / OFF
Stop	ESC position when current consumption above the CURRENT value	500 - 2500 us

Connecting the components:



- Use the three-core lead to connect the **telemetry socket T** on the General Air module to the telemetry socket T on the receiver. Connect the electronic speed controller to the **socket CO**.
- Use a three-core lead to connect the **socket CI** on the General Air module to the receiver socket to which the electronic speed controller would usually be connected.
- Current control can be activated and disabled from the transmitter: for this function you need one vacant switched channel. Connect the associated receiver output to the **socket CS** on the General Air module using a three-core lead.
- Finally connect the flight battery (IN) and the motor (OUT) to the sensor as shown above.

Programming the current limiter:

- The maximum current drawn by your drive motor can be programmed under CURRENT.
- Under ON [XXXXus] you should set the throttle position, at which the module's current limiting function is to begin. The higher the maximum current, the earlier the activation point for the current limiting function. The value is programmed by setting the throttle stick to the appropriate position, then pressing the INC + DEC buttons: the value is then accepted directly on the screen. The value can also be fine-tuned by pressing the INC or DEC button.
- If you wish to be able to switch current limiting on and off from the transmitter using a switched channel (socket CS connected), you must program a throttle stick position [XXXXus] under ON METHOD, since this function is otherwise disabled.
- The </> position can be selected to suit different radio control systems, i.e. if servo reverse is required at the electronic speed controller.
- Set whether current limiting is to be activated (ON) or disabled (OFF) at ON METHOD. If it is activated and the maximum current is exceeded, the controller's current is reduced to the throttle position programmed under STOP until such time as the current drain falls back below the set value. The current is then raised again to the selected throttle position, etc. This means that you can fly at one throttle position, and the current limiting is carried out automatically by the General Air module; all you will notice is a slight fluctuation in motor power.
- Under STOP you can program the speed controller's throttle position to which the current is reduced if the set maximum current is exceeded; it is best to start with a position just above the neutral setting. Exception: if you are using a folding propeller, the controller must apply slight brake to ensure that the blades fold back reliably.
- The value is programmed by setting the throttle stick to the appropriate position, then pressing the INC + DEC buttons: the value is then accepted directly on the screen. The value can also be fine-tuned by pressing the INC or DEC button.
- **Example:**
Settings: maximum current (CURRENT): 40 A, ON [1500us], current limiting active (On Method: ON) and controller position (STOP): 1400 us.

When you advance the throttle stick to the full-throttle position (e.g. 1900us) the motor current rises to 65 A. Since the position is above the set 1500us, and current limiting is active, the General Air module reduces the motor current by lowering the position to the value programmed under STOP. Once the motor current is below 40 A again, the module raises the throttle setting again to the value set by the throttle stick (1900us).

8. SUMMARY SIGNAL TONES



page 15: Min. Altitude

page 13: Min. Power voltage

page 2: Min. cell voltage

page 3: Min. voltage sensor 1

page 7: Min. voltage sensor 2

page 21: Minimum RPM

page 23: Minimum fuel

page 12: Max. capacity

page 11: Max. current

page 14: Max. power voltage

page 22: Maximum RPM

page 16: Max. Altitude

page 18: sink rate per 3 sec.

page 17: sink rate per sec.

page 5: Min. temperature sensor 1

page 9: Min. temperature sensor 2

page 6: Max. temperature sensor 1

page 10: Max. temperature sensor 2

page 4: Max. voltage sensor 1

page 8: Max. voltage sensor 2

page 20: climb rate per 3 sec.

page 19: climb rate per sec.

9. TELEMETRY DISPLAY

If you select SIMPLE DATAVIEW the telemetry data can only be displayed, i.e. it cannot be programmed - in contrast to SETTING AND DATAVIEW. However, the data is represented in graphic form, and this makes it the preferable option when actually operating a model, as it is easier and quicker to read and assess.

You should also read the manual of your remote control system, especially the chapter „telemetry“. The operation is done in the transmitter menu „telemetry“ under the display SETTING & DATA VIEW.

Please note: the menus can only be selected when the receiver is switched on. When you switch the receiver on, it may take a few seconds before the receiver display becomes active and can be selected: > symbol appears at the top right corner of the transmitter display (TX). When the receiver is off, the error message „Can't receive data“ appears.

There may be a slight delay in the screen's response to inputs using the top buttons, since all the settings are transmitted directly to the receiver by wireless means.

Operation with the SMART-BOX:

Switch the transmitter on: the start screen of the SMART-BOX displays SETTING AND DATAVIEW / MODEL SELECT. Use the INC or DEC button to move the arrow cursor to MODEL SELECT, then press ENTER to switch to the graphic representation of the telemetry display.

Please note: these menus can only be selected if the receiver is already switched on. After you switch the receiver on, note that it may take several seconds before the display becomes active, and can be selected. There may be a slight delay in the screen's response to inputs using the top buttons, since all the settings are transmitted directly to the receiver by wireless means.

Once you have selected MODEL SELECT, the Smart-Box displays the telemetry menu. You must then select the appropriate sensor using the arrow cursor, depending on whether you are operating a model aircraft (AIRPLANE) or a model car (CAR).

It is possible to select any of the displays, but - as you would expect - the unit can only display those parameters for which sensors are actually installed in the model; all the other parameters display the value 0.

Use the INC (▲) or DEC (▼) button to move the arrow cursor to AIRPLANE (model aircraft) or CAR (model car), then press ENTER (SET) to move to the corresponding telemetry display.

In the aircraft display (AIRPLANE) you can use the INC or DEC button to select one of the following graphic displays:

RECEIVER: shows the same data as RX DATAVIEW

RECEIVER + GENERAL MODULE: + two additional sensors. As RX DATAVIEW, As RX DATAVIEW, but plus rotational speed (RPM), altitude (ALT), current

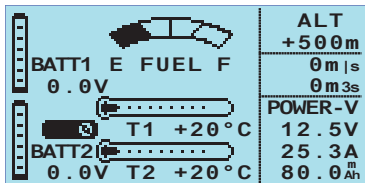
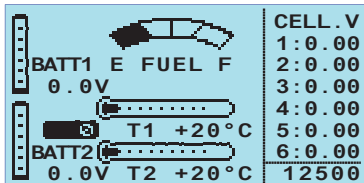

The right third of the display is shown alternately.

Parameter	Description
BATT1 / BATT2	Battery 1 / Battery 2 (socket 5 / 7)
FUEL	Fuel level / Fueltank Indicator (socket 10)
E / F	Empty / Full
T1 / T2	Temperature of sensor 1 / sensor 2 (socket 5 / 7)
CELL.V	Cell Voltage of cell 1 ... max. 6 (socket 6)
>12500<	Current RPM (socket 9)
ALT	Current altitude
0m s	m/1 s climb / descent
0m 3s	m/3 s climb / descent
POWER-V	<ul style="list-style-type: none"> current voltage of drive battery in V electric current of drive battery in A Used capacity in mAh since the start (socket 1)

Multiple sensors, for example GPS and General module, can be connected to the receiver via a Y-cable order No. 3936.11 from software version V2.x or higher for the module, receiver and SMART-BOX.

Attention: When using the Y-cable plugged into the telemetry connector on the receiver for connecting multiple sensors, only the SIMPLE DATA VIEW or MODEL SELECT can be used, because only in this mode the sensors are addressed correctly.

The SETTING AND DATAVIEW mode for programming can not be used!

First the sensors must individually programmed, for example directly with the SMART-BOX.

10. Firmware Update GENERAL AIR-MODULE

Firmware updates for the General Air-Module are transferred conjunction with a PC running Windows XP, Vista or 7. For this you also require the USB interface, Order No. 7168.6, the adapter lead, Order No. 7168.6A and a Y-cable Order No. 3936.11 which are available separately.

The programs and files required for this are available from www.graupner.de in the Download area for the corresponding products.

Install the Firmware Update Utility Graupner and the USB drivers on your computer. Check the system requirements!



The first step is to cut through the central red wire in the adapter lead, Order No. 7168.6A, then connect the lead to the USB interface, Order No. 7168.6. This socket is also polarised; note the small chamfer on one edge. Never use force - the plug should engage easily and fully.

10.1. General Air-Modul

Disconnect the 3-pin lead of the General Air-Module from the receiver. Connect the male connector of the Y-cable in the free socket (T) of the General Air-Module. In one female connector of the Y-cable the adapter cable to the USB interface is plugged, into the second connector a suitable receiver battery to power the update process is connected. Caution: Plug in the receiver battery after pushing the „Program“ button (see point 10.2), or use a switch harness.

10.2. Update procedure

Ensure that the adapter lead is configured as shown in the illustrations, and are connected.

Start the Graupner Firmware Update Utility.

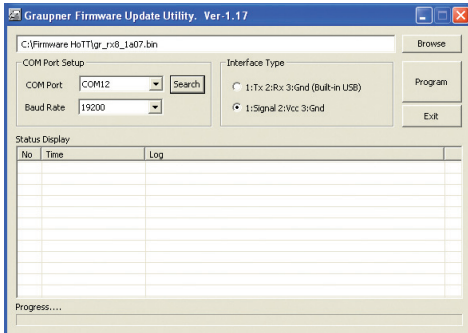

Under [COM Port Setup] select the correct COM port, i.e. the one to which the USB lead is connected. If you are not sure of this, press the button „Search“ and select in the pop-up window „Silicon Labs CP210x USB to UART Bridge“ and press „OK“. Select Baud Rate 19200.

Under [Interface Type] click on Signal 2:Vcc 3:Gnd.

Now click on the “Browse” button and select the folder containing the previously loaded firmware file ending in *.bin. If everything is correct, the file will appear in the corresponding window.

The firmware files are encoded in product-specific form, i.e. if you accidentally select a file which does not match the product (e.g. transmitter update file

instead of receiver file), then the pop-up window “Product code error” will appear, and you will not be able to start the update procedure.

Press the “Program” button in the software. Wait briefly until you see movement in the progress bar. This make take up to five seconds, depending on the computer.

Switch on the power supply (see 10.1), so that the General Air-Module is powered on.

After a few seconds the Status screen displays the message “Found target device...”; you can now release the button, and the firmware update process commences.

If the device is not recognised, if the pop-up window “Target device ID not found” appears, or if the process fails before 100% is reached, you must restart the update procedure. Repeat all the steps as described above.

The Status display and the Progress bar show the progress of the firmware update. The update is completed when the message “Complete...100%” or “Complete!!” appears.

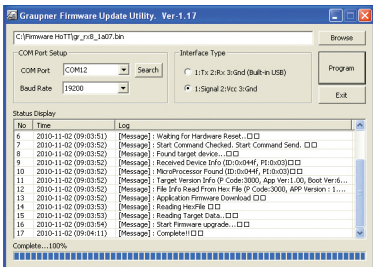
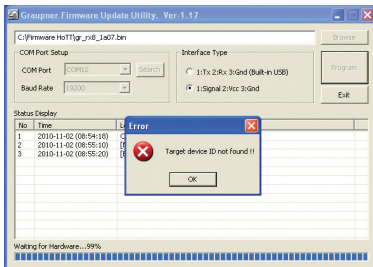

Switch off the power supply and disconnect all leads from the Y-cable. Connect the General Air-Module with the receiver again.

11. SPECIFICATIONS GENERAL AIR-MODUL

Input voltage	max.	60 V DC
	resolution	10 mV
	accuracy	1 %
Current	Shunt resistance	0.0005 Ohm
	continous current	40 A (G3.5 connector)
		5 A (JR-connector)
	peak current (1 s)	60 A (G3.5 connector)
		15 A (JR-connector)
	resolution	0.1 A
accuracy	1 %	
Capacity	max.	30.000 mAh
	resolution	1 mAh
Temperature Sensor 1 / 2	range	- 20° C ~ 200° C
	resolution	1° C
Voltage Sensor 1 / 2	max.	60.00 V DC
	resolution	10 mV
	accuracy	1 %
LiXX cell voltage	Max. number of cells	6
	resolution	10 mV
	accuracy	1 %
Altitude	range	- 500 ~ 3000 m
	resolution	0.1 m
RPM	range	up to 200.000 rpm
	resolution	10 rpm
Fuel	display	0 %, 25 %, 50 %, 75 %, 100 %

EG DECLARATION OF CONFORMITY:

We hereby declare that the following product:

General Air-Module order.-no. 33611

confirms with the essential protective requirements as laid down in the directive for harmonising the statutory directives of the member states concerning electro-magnetic interference 2004/108/EC.

This product has been tested for electro-magnetic interference in accordance with the following norms:

EN 61000-6-1

EN 61000-6-3

This declaration was produced by

Graupner GmbH & Co. KG

Henriettenstr. 94-96

73230 Kirchheim/Teck

and is valid for the manufacturer / importer of the product

73230 Kirchheim/Teck, den

20.12.2010



Stefan Graupner
Managing Director

Environmental Protection Notes

When this product comes to the end of its useful life, you must not dispose of it in the ordinary domestic waste. The correct method of disposal is to take it to your local collection point for recycling electrical and electronic equipment. The symbol shown here, which may be found on the product itself, in the operating instructions or on the packaging, indicates that this is the case.



Individual markings indicate which materials can be recycled and re-used. You can make an important contribution to the protection of our common environment by re-using the product, recycling the basic materials or recycling redundant equipment in other ways.

Remove batteries from your device and dispose of them at your local collection point for batteries.

In case of R/C models, you have to remove electronic parts like servos, receiver or speed controller from the product in question, and these parts must be disposed of with a corresponding collection point for electrical scrap.

If you don't know the location of your nearest disposal centre, please enquire at your local council office.

Garantie von **24** Monaten warrantied for **24** months garantie de **24** mois

Die Fa. Graupner GmbH & Co. KG, Henriettenstraße 94-96, 73230 Kirchheim/Teck gewährt ab dem Kaufdatum auf dieses Produkt eine Garantie von 24 Monaten. Die Garantie gilt nur für die bereits beim Kauf des Produktes vorhandenen Material- oder Funktionsmängel. Schäden, die auf Abnutzung, Überlastung, falsches Zubehör oder unsachgemäße Behandlung zurückzuführen sind, sind von der Garantie ausgeschlossen. Die gesetzlichen Rechte und Gewährleistungsansprüche des Verbrauchers werden durch diese Garantie nicht berührt. Bitte überprüfen Sie vor einer Reklamation oder Rücksendung das Produkt genau auf Mängel, da wir Ihnen bei Mängelfreiheit die entstandenen Unkosten in Rechnung stellen müssen.

Graupner GmbH & Co. KG, Henriettenstraße 94-96, 73230 Kirchheim/Teck, Germany guarantees this product for a period of 24 months from date of purchase. The guarantee applies only to such material or operational defects which are present at the time of purchase of the product. Damage due to wear, overloading, incompetent handling or the use of incorrect accessories is not covered by the guarantee. The user's legal rights and claims under guarantee are not affected by this guarantee. Please check the product carefully for defects before you are make a claim or send the item to us, since we are obliged to make a charge for our cost if the product is found to be free of faults.

La société Graupner GmbH & Co. KG, Henriettenstraße 94-96, 73230 Kirchheim/Teck, Allemagne, accorde sur ce produit une garantie de 24 mois à partir de la date d'achat. La garantie prend effet uniquement sur les vices de fonctionnement et de matériel du produit acheté. Les dommages dus à de l'usure, à de la surcharge, à de mauvais accessoires ou à d'une application inadaptée, sont exclus de la garantie. Cette garantie ne remet pas en cause les droits et prétentions légaux du consommateur. Avant toute réclamation et tout retour du produit, veuillez s.v.p. contrôler et noter exactement les défauts ou vices.

Servicestellen / Service / Service après-vente

Graupner-Zentralservice
Graupner GmbH & Co. KG
Henriettenstrasse 94-96
D-73230 Kirchheim / Teck

Servicehotline
☎ (+49) 01805 47 28 76
Montag - Freitag 7:30 - 11:45
und 12:30 - 16:00 Uhr

Belgie/Niederland
Jan van Mouwerik
Slot de Houvelaan 30
NL 3155 Maasland VT
☎ (+31)10 59 13 59 4

Luxembourg
Kit Flammang
129, route d'Arion
L 8009 Strassen
☎ (+35) 23 12 23 2

Česká Republika/Slovenská Republika
RC Service Z. Hnizdil
Letecká 666/22
CZ-16100 Praha 6 - Ruzyně
☎ (+42) 2 33 31 30 95

Schweiz
Graupner Service Schweiz
CD-Electronics GmbH
Kirchweg 18
CH-5614 Sarrenstorf
☎ (+41) 56 66 71 49 1

Espana
Anguera Hobbies
C/Terasa 14
E 43206 Reus (Tarragona)
☎ (+34) 97 77 55 32 0

Sverige
Baltechno Electronics
P.O. Box 5307
S 40227 Göteborg
☎ (+46) 31 70 73 00 0

France
Graupner Service France
Gérard Altmayer
86, rue St. Antoine
F 57601 Forbach-Oeting
☎ (+33) 3 87 85 62 12

UK
Graupner Service UK
Brunel Drive
GB, NEWARK, Nottinghamshire
NG242EG
☎ (+44) 16 36 61 05 39

Italia
GiMax
Via Manzoni, no. 8
I 25064 Gussago
☎ (+39) 30 25 22 73 2

Garantie-Urkunde

Warranty certificate / Certificate de garantie

33611 General Air-Module

Übergabedatum
Date of purchase/delivery
Date de remise

Name des Käufers
Owner's name
Nom de l'acheteur

Straße, Wohnort
Complete address
Domicile et rue

Firmenstempel und Unterschrift
des Einzelhändlers
Stamp and signature of dealer
Cachet de la firme et signature
du détaillant

Graupner

Graupner GmbH & Co. KG
Henriettenstraße 94 – 96
D-73230 Kirchheim/Teck
Germany
www.graupner.de

Änderungen sowie Liefermöglichkeiten vorbehalten. Lieferung durch den Fachhandel. Bezugsquellen werden nachgewiesen. Für Druckfehler kann keine Haftung übernommen werden.

Specifications and availability subject to change. Supplied through specialist model shops only. We will gladly inform you of your nearest supplier. We accept no liability for printing errors.

Sous réserve de modifications et de possibilité de livraison. Livraison uniquement au travers de magasins spécialisés en modélisme. Nous pourrions vous communiquer l'adresse de votre revendeur le plus proche. Nous ne sommes pas responsables d'éventuelles erreurs d'impression.

Con riserva di variazione delle specifiche e disponibilità del prodotto. Fornitura attraverso rivenditori specializzati. Saremmo lieti di potervi indicare il punto vendita più vicino a voi. Si declina qualsiasi responsabilità per errori di stampa.